

**User Manual &  
Spare Parts Catalogue**

(EN) 10-12-2021

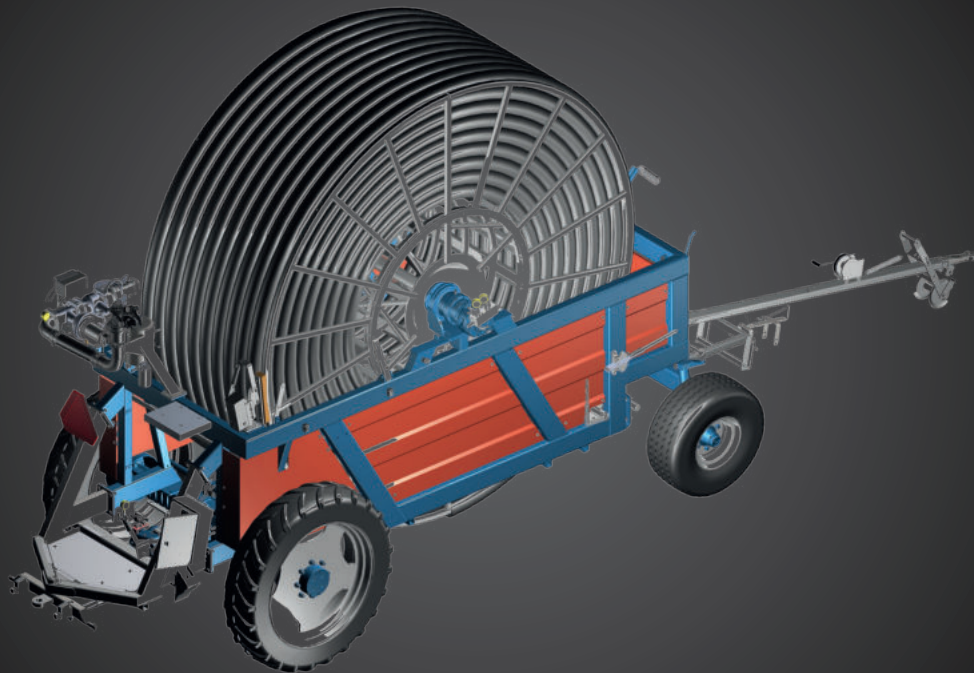

# Irrigator FM4800H



Fasterholt Maskinfabrik A/S  
Ejstrupvej 22  
7330 Brande  
Denmark

Telephone:  
Telefax:  
E-mail:  
Web:

+45 97 18 80 66  
+45 97 18 80 40  
mail@fasterholt.dk  
www.fasterholt.dk

<b>EU Declaration of Conformity</b>	<b>3</b>
<b>General safety</b>	<b>4</b>
Operating instructions for Fasterholt FM 4800H	4
<b>Product labelling</b>	<b>5</b>
Symbols used in this product	5
<b>Operating instructions</b>	<b>7</b>
Starting the FM4800H	7
Preparing the machine for irrigation	7
Preparing the machine after irrigation	8
Maintenance	8
Preparation for winter	9
Faults on the Irrigator	9
<b>Technical data</b>	<b>11</b>
Nelson SR 150	11
<b>Spare parts</b>	<b>32</b>
Front axle and drawbar	32
Front axle	34
Parts on frames	38
Guards	40
Turbine for drum	44
Drum	46
Stop bracket	50
Hydraulics	52
Flat gear	56
Rear drawbar	58
Parts on rear drawbar	60
Turbine installation	62
Turbine	66
Rear axle assembly	72
Rear axle parts	78
Sensor	80
Gun	82

## EEC Declaration of conformity

**Manufacture (name and address):**

**Fasterholt Maskinfabrik A/S**

Adresse: Ejstrupvej 22,  
Fasterholt  
Ort: 7330 Brande  
Country: Denmark  
Web: [www.fasterholt.dk](http://www.fasterholt.dk)

CVR: 58 83 28 12  
TEL: +45 97 18 80 66  
FAX: +45 97 18 80 40  
E-Mail: [mail@fasterholt.dk](mailto:mail@fasterholt.dk)

Hereby is certified that the following product:

Description, ID/mark, type: Irrigator FM 4800H

Serial No. if any: \_\_\_\_\_

Notified body if any: \_\_\_\_\_

EEC-type certificate if any: \_\_\_\_\_

Harmonised standards if any: EN 908:1999+A1:2009.  
DS/EN/ISO 12100:2011.  
DS/EN/ISO 14120:2015.

Is made according to the announcement no.693 of 10. Jun 2013 that implements the DIRECTIV 2006/42/EC.

Name, title and signature of manufacture:

\_\_\_\_\_  
Date

  
Signature

## !!! Important!!!

READ THIS MANUAL BEFORE USING YOUR IRRIGATOR!!

### Operating instructions for Fasterholt FM 4800H

Your new Fasterholt Irrigator is a Danish built machine, but even the best machines only deliver top results when they are properly used and maintained.

To ensure that the machine complies with the EU Machinery Directive, it is important to use the original machine parts. If non-original parts are used, compliance will not be maintained and you will be responsible for your own safety.

The irrigator is intended for irrigation with clean water from a drilled well or a watercourse.

### Safety instructions/warnings!!

- It is forbidden to stand on the machine during irrigation and transport (**risk of fatal injury**).
- The guards are fitted for your own safety - please leave them in place.
- Remember to tighten the wheel bolts.
- When starting the machine on falling ground, you must be **VERY** careful not to disconnect the tractor from the machine until the machine has been put into gear, otherwise the machine may run away.
- If a rear wheel is removed, **THE MACHINE MUST BE JACKED UP AND VERY STABLE**, because if it overturns, it will fall completely on its side.

### WARNING!!

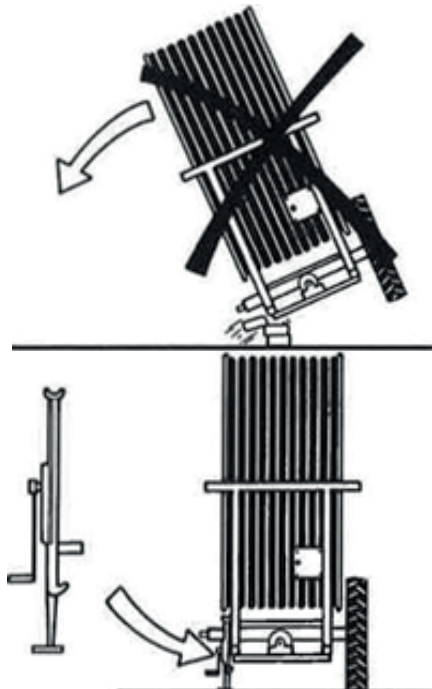

- To perform an EMERGENCY STOP, pull the cable for the miswinding bar or press STOP on the COMPUTER.
- The gun must face out to the side when unwinding the machine.
- **STAND ASIDE** when the gun is operating.
- **WARNING** against contact with overhead power lines with the machine or water jet. Avoid irrigation on or near power lines.
- During transport on uneven roads/fields, move **VERY** carefully according to the conditions.
- Max. transport speed with water in the hose is 15 km/h.
- When parking the machine, use the wheel chocks mounted by the rear wheels.
- **DANGER!!** Avoid welding in the paint layer! Before welding, remove all paint from the welding area.
- Avoid inhalation of grinding dust.
- Hydraulic oil can be harmful to health:
- Skin contact may cause allergies.
- Inhalation of oil mist may cause lung disease.
- Leakage of oil under high pressure is dangerous, an oil jet can enter the skin, eyes, etc.
- If a hydraulic system leak is found, stop the system immediately and rectify the fault.
- Note that due to operation, the oil may be 70 degrees Celsius or even hotter. This can lead to a risk of scalding during separation.
- **IMPORTANT.** Maximum battery charging power is 2 amps. Charging more than 2 amps may cause the battery to crack. The battery must be charged at a temperature between 0 °C and +40 °C. Avoid sparks and flames on and around the battery.
- Do not short circuit the battery.
- Never disassemble the battery.
- If you come into contact with the battery's sulphuric acid, wash immediately with water. If acid comes into contact with eyes, rinse thoroughly with water and seek medical attention immediately.
- Pay attention to the battery compartment. If there are cracks, deformities, electrolyte leakage, etc., replace the battery immediately.
- If the battery is dirty, clean it as soon as possible.
- Disposal of oil spills:
- If oil spills are found, they should be cleaned up immediately with rags or oil absorbent powder.
- Spilled products, as well as rags and powder used for oil spills, must be stored in sealed metal containers and delivered to the municipal collection site.
- Batteries, hoses, tyres and other parts of the irrigation machine must be disposed of at an approved recycling site.

If the machine is to be moved via public roads, it must first be drained of water.

## Symbols used in this product

The following symbols are used in this product and the following documentation.



**WARNING** Indicates a potentially dangerous situation which, if not prevented, could result in death or serious injury.



**LUBRICATION** Indicates lubrication is required as per the service description



**SERVICE WARNING** Indicates a service hazard



## Starting the FM4800H

Move the machine to the field in the transport position. When the machine is at the crop to be irrigated, disconnect the tractor from the front drawbar. Connect the tractor to the rear drawbar. Insert the electric brake connector in the female connector for the tractor lights. The machine then winds up in the crop and stops.

**Disengage the stop pawl at the hose drum.**

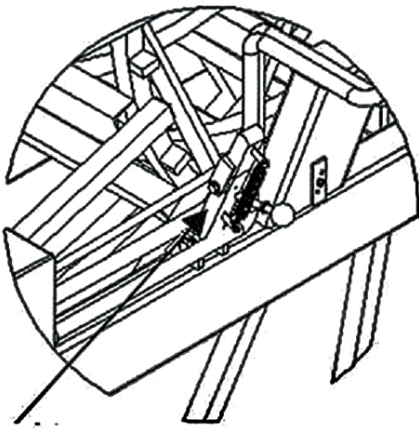

The stop pawl at the hose reel is disengaged when laying the hose.

**Remember!!** When starting the machine on falling ground, you must be **VERY careful not to disconnect the tractor from the machine until the machine has been put into gear, otherwise the machine may run away.**

### Safety stop

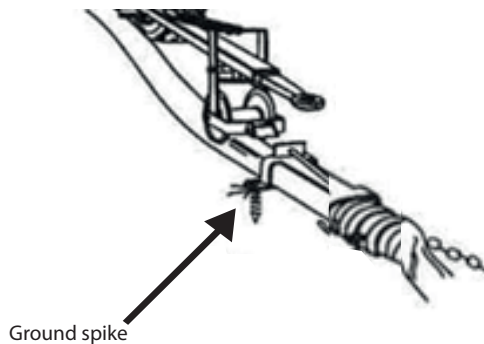
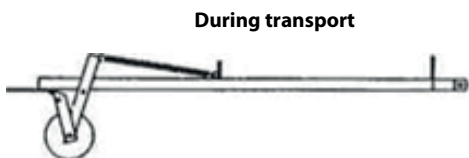
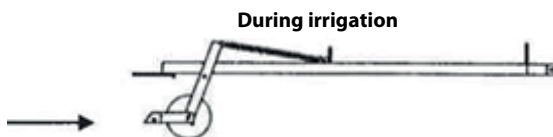

Secure the long ground spikes. Lower the drawbar over the hose, and release the safety stop so the hose reel runs on the hose.

**The machine should be unwound completely at least every 3rd time.** Before starting to unwind the machine, reset PROGRAM RAIN. To do this, press the TOGGLE SWITCH located on the side of the electric box upwards (reset).

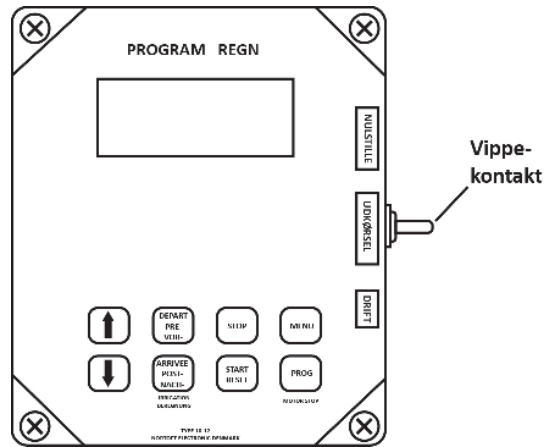

When unwinding the machine, the TOGGLE SWITCH must be in the centre (unwind) so it cannot reset on the way out. After unwinding, press the TOGGLE SWITCH down (operation).

**ALWAYS REMEMBER that the TOGGLE SWITCH must be pressed down during operation, otherwise the machine will not move.**

Unwind the machine at **max. 5 km/h** to keep the hose tight on the drum at all times with the electric brake. If you do not lay the hose straight out be **very careful** to ensure that the hose is always tightened on the hose drum.

### Preparing the machine for irrigation

**Disengage the stop pawl at the hose to enable operation. Also remember to release the electric brake and disconnect the electric brake connector from the tractor.**

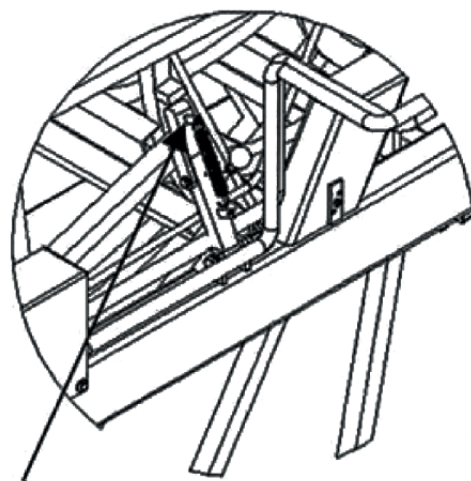

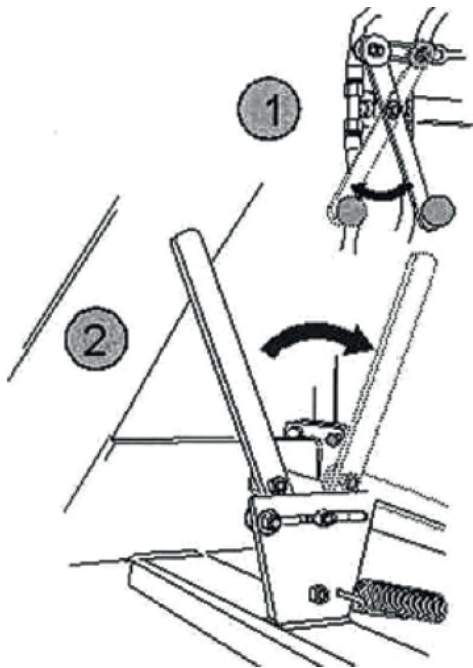

Remember to close the decoupling valve (**Lever "1" must be pulled out**) and to engage with the coupling lever. (**Lever "2" pulled out**)

Attach the charge hose to the hydrant. Then open the hydrant, start the pump and irrigation can begin. When starting irrigation, see the operating instructions for PROGRAM RAIN. Put the machine in gear. (Remember to select the right gear for the speed you want to drive at.) (Refer to table below or on the machine for electrical control.)

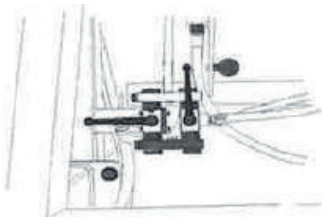

**1.GEAR**  
20-30 meter  
pr. time

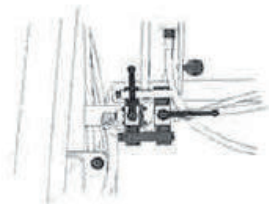

**2.GEAR**  
30-45 meter  
pr. time

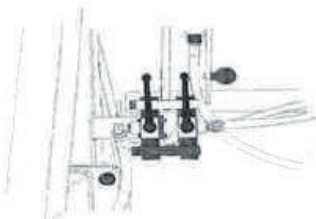

**3.GEAR**  
45-90 meter  
pr. time

**Preparing the machine after irrigation**

After each irrigation, open the bypass valve (**Lever "1" must be pushed in**) to get the gearbox out of gear (**Lever "2" pulled out**). If there is tension in the rear axle assembly, use a fork wrench to turn the input shaft to release the coupling.

**ALWAYS REMEMBER THAT THE COUPLING MUST BE RELEASED (COUPLING LEVER PULLED BACK) WHEN THE MACHINE IS NOT MOVING BY ITSELF.**

**Maintenance**

**1x per week:**

Check that no water is entering the oil on the rear axle assembly and hydraulic system. Lubricate the steering, roller chain for hose guides, roller chain for forward traction, cross track shaft for hose guide with water-repellent grease.

Check tyre pressure:

Rear wheel air pressure: FM4800H: 2.9 bar

Front wheel air pressure: FM4800H: 4.1 bar

Check that front and rear drawbars line up.

**Clean the filter at the turbine outlet if required**

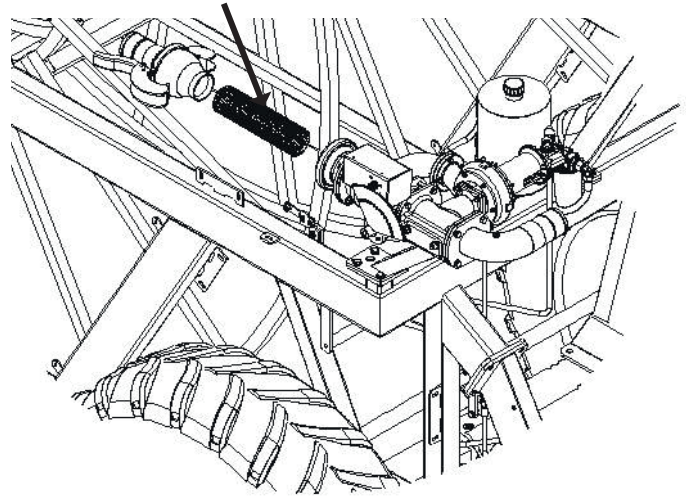

Check that the hose is positioned neatly on the hose drum. Remember to check the guide pins in the hose guides regularly.

Remember to tighten the wheel bolts regularly.  
Tighten rear wheel bolts to: 450 Nm  
Tighten front wheel bolts to: 330 Nm



**NOTE:**

The battery should be charged once a month during the season to maintain full power and extend its useful life.

**Preparation for winter**

**Drain water from the machine:**

Water can only be drained from the machine with air. Use the special compressor for draining.

**REMEMBER!!**

Open the filter coupling.

**Open the valve in the base of the turbine**

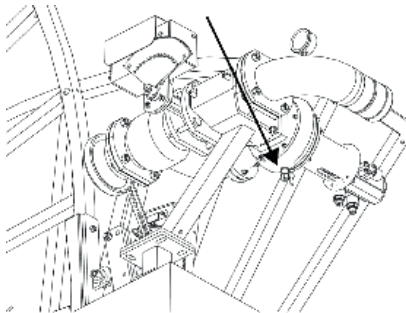

On machines with high pressure stops START to open the main valve and allow the water to flow out freely. (Disconnect battery lead so stop valve does not close again.)

**Remove the battery and do not install it until the next time you use the machine.**

Lubrication of:

Front wheel hubs, front spindle, hose guides, bearings on hose guides, wheels.

Check for water in the oil in the rear axle assembly and hydraulic tank. Oil in the rear axle assembly / flat gear should be changed every 1,000 hours. Hydraulic oil and filter should also be replaced every two years.

Lubricate the steering, roller chain for hose guides, roller chain for forward traction, cross track shaft for hose guide with water-repellent grease.

Check tyre pressure:

Guide pins should be replaced every year.

Check the following before calling a technician:

1. If the machine is irrigating, but not moving:
  - a. Check that machine is in gear.
  - b. Check if it is performing pre-irrigation or post-irrigation. (can be seen on the display under menu 3.)
  - c. Check if pressure drop valve is closed.
  - d. Check that end stop sensor is in place. (Can be seen on the display under menu 2.)

**Faults on the Irrigator**

- e. Check that toggle switch is in operation position.
- f. Check that decoupling valve is closed (for hydraulic motor).

- g. Check that filter at turbine outlet is not blocked.
- h. Check that turbine can turn easily.

2. If the machine does not wind up the hose properly, it may be that:
  - a. The hose guide needs to be adjusted: To adjust the guide, remove the chain from the hose guide to the cross track shaft. Then turn the cross track shaft until the hose guide fits the hose again. Then fit the chain.
  - b. The guide pin is worn and needs to be replaced.
  - c. There is not enough pressure on the drum winder. (call a technician).
3. Front and rear forced steering are not aligned and forced steering is sprung on impact:
  - a. There is a leak at the coupling or assemblies, so the oil has drained out, leaving air in the system.
  - b. The system must be vented. (call a technician).

**Data for FM4800H with dual pump**

Hose PEL 110 mm:

Capacity up to 75m<sup>3</sup> - hose length from 500 to 675 m.

Hose PEL 125 mm:

Capacity up to 100m<sup>3</sup> - hose length from 400 to 550 m.

Wheel size:

Rear wheels: 12.4" x 36" x 10 ply: 2.9 bar

Front wheels: 13.0"/75 x 36" x 10 ply: 4.1 bar

Speed at 55 m3 and above:

20 - 70 m per hour

Weight of FM4800H:

Weight without water with 675 m/110 mm hose:

5,000 kg.

Weight with water with 675 m/110 mm hose:

9,300 kg.

Track width:

2010 mm

Gun:

Nelson SR 150

Oil and lubrication:

Oil in rear axle assembly:

25 litres 80/90 gear oil

Oil in flat gear:

1.5 litres 80/90 gear oil

Oil in oil motor gear:

3.5 litres 80/90 gear oil

(every 2 years)

Hydraulic oil (Tank):

14 litres STATOIL  
Hydraway HVXA 46

Grease for lubrication:

STATOIL Moly Way  
EP2 or equivalent.

Width:

230 cm

Length without drawbar:

608 cm

Length with drawbar:

893 cm

Height:

397 cm

Optional equipment:

Electric brake set with brake block.



Nelson SR 150 is factory-adjusted to Danish conditions and ready to use after the following three steps:

1. Select and install the nozzle size that best suits your application. Performance data for the different sizes are show
2. Adjust the stop on the part circle to obtain the desired irrigation angle.
3. There is a grease nipples which should be checked once a week for refilling.

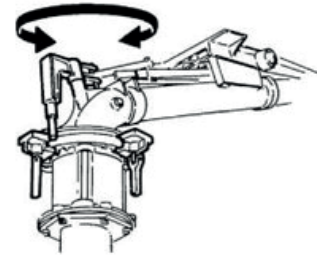

## ADJUSTMENT

The only thing you can adjust is the counterweight on the drive arm.  
 By moving the counterweight forward, the gun will slowly irrigate from side to side. If you move the counterweight back, the gun will irrigate quickly. If it does not irrigate quickly enough, you can remove the brake springs (no. 778474) in pairs (contact the service department).

**WARNING: DO NOT ADJUST WHEN THE GUN IS IRRIGATING!!**

**DANGER.....: HIGH WATER PRESSURE – STAY CLEAR!!**

**TABLE FOR NELSON SR 150**

Dysetabel for Nelson SR150 kanon, 21°- Plastdyser.

Tryk (Bar)	18mm		19mm		20mm		21mm		22mm		23mm		24mm	
	m <sup>3</sup> /h	Rad.(m)	m <sup>3</sup> /h	Rad.(m)	m <sup>3</sup> /h	Rad.(m)	m <sup>3</sup> /h	Rad.(m)	m <sup>3</sup> /h	Rad.(m)	m <sup>3</sup> /h	Rad.(m)	m <sup>3</sup> /h	Rad.(m)
3,5	20,2	32,5	22,7	33,5	25,4	34,5	28,0	36,0	30,9	36,5	34,1	37,5	37,5	38,8
4,0	21,6	33,5	24,3	34,5	27,1	35,7	29,9	36,5	33,0	37,8	36,4	38,8	40,1	40,0
4,5	22,9	34,5	25,7	35,7	28,7	36,5	31,7	37,8	35,0	39,2	38,6	40,5	42,5	41,4
5,0	24,2	35,2	27,1	36,5	30,3	37,8	33,4	39,2	36,9	40,5	40,7	41,4	44,8	42,7
5,5	25,3	36,5	28,5	37,8	31,7	38,7	35,1	40,0	38,7	41,4	42,6	42,7	47,0	44,0
6,0	26,5	37,4	29,8	38,7	33,1	40,0	36,6	41,4	40,4	42,7	44,5	44,0	49,0	45,3

Tryk (Bar)	25mm		26mm		27mm		28mm		29mm		30mm		31mm	
	m <sup>3</sup> /h	Rad.(m)	m <sup>3</sup> /h	Rad.(m)	m <sup>3</sup> /h	Rad.(m)	m <sup>3</sup> /h	Rad.(m)	m <sup>3</sup> /h	Rad.(m)	m <sup>3</sup> /h	Rad.(m)	m <sup>3</sup> /h	Rad.(m)
3,5	41,0	39,6	44,8	40,5	49,0	41,8	53,3	42,7	57,9	44,0	62,8	44,8	67,8	45,8
4,0	43,8	40,9	47,8	42,2	52,3	43,1	57,0	44,5	61,9	45,8	67,1	46,6	72,5	47,5
4,5	46,5	42,7	50,7	43,6	55,5	44,5	60,5	45,8	65,7	47,0	71,2	48,0	76,9	49,3
5,0	49,0	44,0	53,5	44,5	58,5	46,2	63,8	47,5	69,2	48,4	75,1	49,7	81,1	50,6
5,5	51,4	44,5	56,1	46,2	61,4	47,5	66,9	48,8	72,6	50,2	78,7	51,0	85,0	52,4
6,0	53,7	46,2	58,6	47,5	64,1	48,8	69,9	49,7	75,8	51,0	82,2	52,4	88,8	53,7

Tryk (Bar)	32mm		33mm		34mm	
	m <sup>3</sup> /h	Rad.(m)	m <sup>3</sup> /h	Rad.(m)	m <sup>3</sup> /h	Rad.(m)
3,5	73,1	46,6	78,7	47,5	84,5	48,4
4,0	78,1	48,4	84,2	49,3	90,3	50,2
4,5	82,9	50,2	89,3	51,0	95,8	51,9
5,0	87,4	51,9	94,1	52,8	101,0	53,2
5,5	91,6	53,2	97,8	54,1	105,9	55,0
6,0	95,7	54,6	103,0	55,4	110,6	56,3





**Functions:**

Speed regulator  
 Pre- and Post-irrigation  
 4 different speeds on sections of the lane  
 Clock  
 Setting the start time  
 Stop time is shown on the display  
 Length of hose  
 Current speed  
 Battery volts  
 Charge regulator

Pressure sensor  
 Stop sensor  
 Speed sensor  
 Motor 1, regulating motor  
 Motor 2, stop motor  
 Slow start of turbine  
 Slow closing of inlet  
 Water volume + spreading width

**Accessories:**

GSM, SMS messages for remote control.  
 Analogue pressure sensor.

Short instructions for use



Place machine:

SPEED	30.0m/h
DOSE	22 mm
TIME	7:28 STOP 7:28
STATUS	STOP Sensor

Move machine to a new lane. Display shows start and stop time. Pull hose out to end of the lane. (e.g. 250 m)

Select Speed:

SPEED	30.0m/h
DOSE	22 mm
TIME	7:56 STOP17:16
STATUS	STOP Sensor

Display now shows stop after 9h 20m. Press the "+" or "-" key to set the speed. Speed can be adjusted during irrigation.

SPEED	25.0m/h
DOSE	26 mm
TIME	7:58 STOP17:58
STATUS	STOP Sensor

SPEED has decreased, **DOSE** has increased and **STOP** time is later.

Start Irrigate, Select PRE- and POST Irrigation.

SPEED	25.0m/h
DOSE	26 mm
TIME	7:58 STOP17:58
STATUS	STOP Sensor

Press START to start. Press **PRE** and **POST** for pre- and post-irrigation respectively. STOP time will be later when PRE and POST irrigation are selected.

Starting:

SPEED	25.0m/h
DOSE	26 mm
TIME	8:00 STOP18:38
STATUS	Running

The turbine will start when the water pressure increases. After a short period, the regulator finds the correct speed. Irrigation continues until STOP SENSOR is activated at the end of the lane.

-PRE Irrigation

SPEED	25.0m/h
DOSE	26 mm
TIME	8:02 STOP18:38
STATUS	PRE Irrigate

If pre-irrigation is selected, the turbine stops immediately after performing a start and pre-irrigation. When the pre-irrigation time has elapsed, the turbine starts and the machine changes status to Irrigating.

-POST Irrigation

SPEED	25.0m/h
DOSE	26 mm
TIME	18:20 STOP18:38
STATUS	POST Irri.

If post-irrigation is selected, the turbine stops at the end of the lane when the stop sensor is activated. Post-irrigation then starts.

Stop:

SPEED	25.0m/h
DOSE	26 mm
TIME	18:38 STOP18:38
STATUS	STOP Sensor

Stop sensor is activated, turbine and water are shut off. The machine is now ready to be moved to a new lane.

General instructions for use

MENU's

```
SPEED      30.0m/h
DOSE       22 mm
TIME 14:10 STOP 7:43
STATUS Running
```

Standard display

```
ZONE      1 30.0m/h
DOSE      22 mm
TIME 14:10 STOP 7:43
STATUS Running
```

Standard display, ZONE irrigation is selected.

```
DISTANCE   123m
BATTERY    12.8V
CHARGE ON  0.231A
PRE. 0:45 POST 0:45
```

Press the **MENU** key 1 time to display menu 2

```
PRESS SENSOR
STOP SENSOR
SPEED SENSOR
MOT1 0.0A MOT2 1.8A
```

Press the **MENU** key 2 times to display menu 3

```
ACTUAL SPEED 22m/h
START        0:00
STOP        7:45
WORKING HOURS 123h
```

Press the **MENU** key 3 times to display menu 4

```
0m 30.0m/h 0m
0m 30.0m/h 0m
0m 30.0m/h 0m
0m 30.0m/h 0m
```

Press the **MENU** key 4 times to display menu 5

```
SIGNAL 23
NETWORK HOME
A: +45123456
B: +45234567
```

Press the **MENU** key 5 times to display menu 6  
(Only if GSM is selected)

When **■** appears in the display, this indicates that the relevant function is ON.

Standard menu:

<b>SPEED</b>	<b>30.0m/h</b>
<b>DOSE</b>	<b>22 mm</b>
<b>TIME 14:10 STOP 7:43</b>	
<b>STATUS Running</b>	

Standard display

- SPEED** Speed. Can be changed at any time during irrigation using the "+" and "-" keys.
  
- ZONE** Current zone 1...4, with corresponding speed. The speed cannot be changed. (Zone active)
  
- DOSE** The dose is calculated from the speed and constants and shows the current number of mm for irrigation. As SPEED increases, DOSE decreases. (Constants 11 and 12)
  
- TIME** To set the time: Set SPEED to 11.1 m/h and press the **PROG** key 3 + 1 times until the display shows <CONST 1 TIME>. The time can then be set with the "+" and "-" keys. When the battery has been disconnected, the clock will show 0:00 until it is set again.
  
- STOP** The time that irrigation is completed, incl. pre- and post-irrigation. If the clock is not set and shows 0:00, the total irrigation time is displayed.
  
- STATUS** Irrigation status, e.g.:
  - < Stop sensor >
  - < Irrigating >
  - < Pre-irrigating >
  - < Post-irrigating >
  - < LOW pressure >
 See explanation in STATUS chapter.

If the display shows: **LOW BATTERY** instead of SPEED, the battery voltage is below 11.8 V and the battery needs to be charged.

MENU 2

<b>DISTANCE</b>	<b>123m</b>
<b>BATTERY</b>	<b>12.8V</b>
<b>CHARGE ON</b>	<b>0.231A</b>
<b>PRE. 0:45 POST 0:45</b>	

- DISTANCE Length of the unwound hose. The length can be changed immediately after pressing the **PROG** key 3 times, using the "+" and "-" keys.
  
- BATTERY Battery voltage.
  
- CHARGER ON Shows when the battery is being charged by a solar cell. The battery is charged when the voltage is below 14.0 volts.
  
- PRE Shows the pre-irrigation time.
  
- POST Shows the post-irrigation time.
  
- The pre- and post-irrigation times can be changed immediately after pressing the **PRE-** or **POST-** keys, using the "+" and "-" keys.

MENU 3

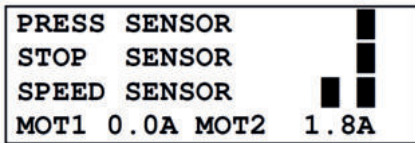

PRESSURE SENSOR

Shows that the pressure is high when block is lit. **The machine can only move when the pressure is high.** If no pressure sensor is fitted (machine data 14 = 0), the machine will operate regardless of pressure status.

The machine can be fitted with analogue pressure sensors. Sensors must be connected according to the diagram. Pressure sensor functions, except for pressure display, are the same as for digital pressure sensors. There are constants for the pressure sensor type. Similarly, set point and hysteresis can be selected for each machine.

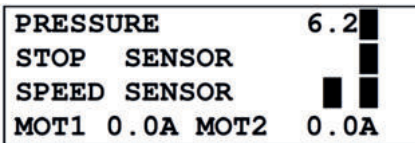

Shows pressure in [BAR] (00.0) or [PSI] (000). Pressure is high when ■ is lit.

**The machine can only move when the pressure is high.**

If no pressure sensor is fitted (machine data 14 = 0), the machine will operate regardless of pressure status.

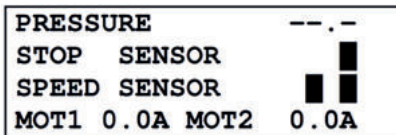

STOP SENSOR

Shows that the magnet is aligned with the stop sensor when block is lit.

**The machine can only start when the magnet is aligned with the stop sensor.**

The stop sensor has 3 functions:

1. Reset distance.
2. Post-irrigation.
3. Stop pulses to the regulator motor.

SPEED SENSOR

For the speed sensor test, block is only lit when the magnet passes the sensor.

MOT1, MOT2

Displays the current motor current. When the current exceeds 4.5 A, the motor stops.

**If the current exceeds 4.5 A and the valve is not in the outer position, there may be a blockage in the valve.**



MENU 4

<b>ACTUAL SPEED</b>	<b>22m/h</b>
<b>START</b>	<b>0 : 00</b>
<b>STOP</b>	<b>7 : 43</b>
<b>WORKING HOURS</b>	<b>123h</b>

**CURR. SPEED** Shows the current speed. That is, the speed at which the machine is moving now. This can be used to find how fast the machine can move. The current speed may differ slightly from the set speed, especially at the start. This does not matter, as regulation ensures that the average speed within 10 metres is correct.

**START** Start machine delay. The machine start time can be delayed by up to 24 hours. To set the start time, press the **PROG** key 3 times, then set the time using the "+" and "-" keys.

**STOP** The time that irrigation is completed with a delayed start.

**OPERATING HOURS** Shows how many hours the machine has been running since the electronics started for the first time.

MENU 5

<b>0m</b>	<b>30 . 0m/h</b>	<b>0m</b>
<b>0m</b>	<b>30 . 0m/h</b>	<b>0m</b>
<b>0m</b>	<b>30 . 0m/h</b>	<b>0m</b>
<b>0m</b>	<b>30 . 0m/h</b>	<b>0m</b>

This menu is for irrigation at different speeds in zones of the lane.  
 Press the **PROG** key 3 times to program the zones.  
 See later chapter for details.

## MENU 6

<b>SIGNAL</b>	<b>23</b>
<b>NETWORK</b>	<b>HOME</b>
<b>A:</b>	<b>+45123456</b>
<b>B:</b>	<b>+45234567</b>

SIGNAL GSM signal strength.  
 NETWORK GSM network.  
 A: First number on "SMS" list.  
 B: Second number on "SMS" list.

See GSM chapter for details.

**START:**

The turbine can only start if the magnet is aligned with the end stop sensor (or end stop sensors). See menu 3 for control of the STOP SENSOR. Press the **START** key to turn on the water. The regulator valve for bypass around the turbine then closes. (Turbine starts). If the end stop sensor is not in place, only the main valve can be opened, which then immediately closes again. Used to relieve pressure before removing charge hose from hydrant.

**DEFERRAL OF START TIME**

First press the **STOP** key to shut off the water supply. Then press the **MENU** key 3 times and **PROG** 3 times. The start time can be set using the "+" and "-" keys. Finally, select pre- and post-irrigation. To exit, press **MENU**. Info: The clock can only be set forwards.

**STOP:**

When the magnet is removed from the end stop sensor, the turbine stops and the main valve shuts off the water (turns on the water at negative pressure). If post-irrigation is selected, rewinding stops when the magnet is removed from the sensor. When the post-irrigation time has elapsed, the main valve closes. When the **STOP** key is pressed, the turbine stops immediately and the main valve shuts off the water, regardless of whether post-irrigation is selected.

**SUPERVISION:**

Program Rain has a built-in supervision system. The supervision system will be activated if for any reason the machine has water in the same location for longer than a specified time. This time is factory-set to 20 minutes. If the time is set to 0, there is no supervision. (See constants on page 17 for setting the supervision time.) If speed supervision less than 50 % of pre-selection is required, select speed supervision together with the above time.

**SPEED:**

The speed is set using the "+" and "-" keys. First count up in steps of 0.1 m/h. After 10 steps, count up in steps of 1 m/h. The speed can be changed at any time during irrigation. If the speed changes during irrigation, the dose and time for the remaining irrigation will be calculated immediately based on the new speed.

**PRE-IRRIGATION:**

If pre-irrigation is required, press the **PRE-** key. The pre-irrigation time is calculated as 8 x the time to move 1 m at the current speed. The constant can be changed individually for pre- and post-irrigation. (See constants). If pre-irrigation is selected, the machine will move forward approx. ½ m, after which the machine will stop and stand still for as long as pre-irrigation is performed. Menu 2 shows the number of minutes remaining of the pre-irrigation time. If you want to cancel pre-irrigation, press the **START** key. This will cancel both pre- and post-irrigation and the turbine will start.

**POST-IRRIGATION:**

If post-irrigation is required, press the **POST-** key. The post-irrigation time is calculated as 8 x the time to move 1 m at the current speed. The constant "8" can be changed individually for pre- and post-irrigation. (See constants on page 17). Post-irrigation starts counting down when the magnet is removed from the stop sensor. When the stop sensor is activated, the turbine stops and post-irrigation starts counting down (see menu 2). When the post-irrigation time has elapsed, the main valve closes. (Opens in installations with negative pressure stops). For machines with mechanical end stops: The turbine stops when the stop sensor is activated. When the post-irrigation time has elapsed, the turbine starts and the machine moves to the mechanical end stop. Press **START** to cancel post-irrigation. If constant "8" (early stop) is selected, the machine will stop when it reaches the selected distance.

**PROGRAMMING 4 DIFFERENT SPEEDS:**

The hose must be unwound before programming, so the computer knows the number of metres in the irrigation lane. The following example assumes that the unwound hose is 400 m. Press the **PROG** key 3 times and the display will show:

400m	30.0m/h	0m
0m	30.0m/h	0m
0m	30.0m/h	0m
0m	30.0m/h	0m

The desired speed can now be selected, in this case 25.0 m/h. Press the **PROG** key and the display will show:

400m	25.0m/h	0m
0m	30.0m/h	0m
0m	30.0m/h	0m
0m	30.0m/h	0m

The desired distance can now be selected, in this case 300 m. Press the **PROG** key and the display will show:

400m	25.0m/h	300m
300m	30.0m/h	0m
0m	30.0m/h	0m
0m	30.0m/h	0m

Now that the first zone is programmed, apply the same procedure to all 4 zones. Zone 4 automatically ends at 0. When zone 4 is programmed, press the **PROG** key again and the display will show:

<b>DELETE</b>	<b>PRESS</b>	<b>MENU</b>
<b>SAVE</b>	<b>PRESS</b>	<b>PROG</b>

If **PROG** is pressed, the program is stored and irrigation will be performed according to this program.

If **MENU** is pressed, the program is deleted and the speed is the same for the entire irrigation lane.

<b>STATUS</b>	Status line in display
<b>**IRRIGATING**</b>	The machine has not started, but speed signals are being received and it is attempting to maintain the selected speed.
<b>IRRIGATING:</b>	The machine is irrigating and functions as intended.
<b>LOW PRESSURE:</b>	Water pressure is low. Individual action according to constants and machine data.
<b>STARTING:</b>	User has pressed the <b>START</b> key and start sequence is being performed.
<b>START TELE:</b>	The machine is starting after receiving an <b>SMS</b> .
<b>START TIMER:</b>	The machine is waiting for start delay. (See Menu 4).
<b>START PRESS:</b>	The machine is performing a start after pressure rise. The machine uses the pressure level to start a second machine on the ground line.
<b>START REJECTED:</b>	User is pressing the <b>STOP</b> key to block <b>PRESSURE</b> and <b>SMS</b> start.
<b>STOP USER:</b>	User has pressed <b>STOP</b> and the machine has stopped.
<b>STOP TELE:</b>	The machine has received an <b>SMS</b> with <b>STOP</b> and has stopped.
<b>STOP SENSOR:</b>	The machine has reached the end and is stopped by <b>STOP SENSOR</b> .
<b>STOP DIST:</b>	The machine has reached the stopping distance. (See constant for early stop)
<b>STOP DELAY:</b>	The machine has reached the end, but waiting xx seconds to perform the stop sequence.
<b>STOP REJECTED:</b>	User is pressing the <b>START</b> key to block <b>SMS</b> stop.
<b>STOP MONITOR:</b>	Monitoring has stopped the machine. The machine has not moved for xx minutes. (See constant for monitoring).
<b>CREATE PRESSURE DROP:</b>	The machine is creating a pressure drop to stop the main pump. After 2 minutes, the valve closes to prevent draining the ground line.
<b>PRE-IRRIGATING:</b>	The machine is performing pre-irrigation.
<b>POST-IRRIGATING:</b>	The machine is performing post-irrigation.

**There are a variety of constants that can be modified by the user.**

These constants will be stored for many years, even if the battery is removed.

**Programming procedure:**

Adjust the speed to 11.1 m/h to access the constants.

Press the **PROG** key 3 times in quick succession to access and change the constants.

Press the **PROG** key again to count forward to the constant you wish to change.

Press "+" and "-" to adjust the value of the constant.

Press the **MENU** key to save the change and the display will return to normal.

If the **MENU** key is not pressed, the display will return to normal after 1 minute and the change will not be saved.

**CONSTANTS**

Cons no.	Note	Fact. Adj.	Min. Value	Max. Value	Description
0		100	-	-	Enter 111 to reach machine data
1		00:00	00:00	23:59	Time in line 2 is set
2		8	1	15	Pre irrigation
3		8	1	15	Pre irrigation
4		20	0	99	Supervision time [minutes]
5		1	1	15	1 English, 2 Danish, 3 German, 4 French, 5, Dutch 6 Swedish, 7 Spanish, 8 Italian, 9 Polish, 10 Japanese 11 Hungarian
6		0	0	2	0 = Stop for high pressure slow shutdown 1 = Stop for low pressure. valve opens and close again after 3 minutes 2 = Motor for stop disconnected
7		-	0	1000	Actual distance, can be set by the keyboard [m]
8		0	0	1000	Early stop [m] (* Is only performed when Post Irrigation is selected *)
9		0	0	1000	Post irrigation before stop [m]
10		0	0	1000	Distance for alarm [m] (* Disabled if Machine data 22. Sprinkler, is selected *)
11		40	5	120	Water flow [m3/h]
12		60	5	100	Spacing between irrigation lanes [m]

Set Constant no. 0 to 111 to set the machine data.

Then press **PROG** to display the machine data.

**MACHINE DATA**

Machine data Number Flashing digit		Possible setting	Factory setting
0	Hose length	0 - 1000 m	Not used
1	Hose diameter	40 - 200 mm	110
2	Hose drum int. Diameter	500 - 3000 mm	Not used
3	Number of hose turns per layer	5.00 - 30.00	15
4	Large gear on hose drum	50 - 1000	Not used
5	Small gear on gearbox	5 - 40	Not used
6	Number of magnets	1 - 20	Not used
7	Ovality compared to 100 %	0.70 - 1.00	0.85
8	Length of first pulse to stop valve	0 - 45 sec.	3
9	Length of subsequent short pulses to stop valve	0 - 300 m/sec.	160
10	Time between short pulses to stop valve	1 - 5 sec.	2
11	Number of short pulses to stop valve	0 - 250	100
12	Mechanical stop (with only 1 motor) Electrical stop (closed low pressure) even if the pressostat registers low pressure	0 1	1
13	Length of pulse to regulator motor at start-up (Oil pump Motor 1)	26.1 - 0.9 sec.	4.5
14	Pressostat not connected Pressostat connected (to start/stop) or Radio start Pressostat installed: (can be used (for start only) for 2 machines on the same system, Autostart with special pressostat.)	0 1 2	1
15	Length machine moves per pulse: 0 = Moves according to formula FM4300 & FM4300H = 73.5 mm (2 magnets) FM4300 & FM4300H = 38.8 mm (4 magnets)  FM4400 & FM4400H = 46.2 mm (4 magnets) Old Rear axle assembly FM4400 & FM4400H = 46.0 mm (4 magnets) New Rear axle assembly  FM4500 & FM4500H = 85.0 mm (2 magnets) FM4500 & FM4500H = 42.5 mm (4 magnets)  FM4550 & FM4550H = 46.2 mm (4 magnets) Old Rear axle assembly FM4550 & FM4550H = 46.0 mm (4 magnets) New Rear axle assembly  FM4800H = 43.3 mm (4 magnets) Old Rear axle assembly FM4800H = 46.0 mm (4 magnets) New Rear axle assembly  FM4900H = 103.0 mm (2 magnets) FM4900H = 51.5 mm (4 magnets) FM4900H = 46.8 mm (4 magnets) New Rear axle assembly  FM5500H = 47.0 mm (4 magnets) FM5500H = 47.0 mm (4 magnets) New Rear axle assembly 62.5 = When moving with roller Ø80 [mm] 0 = Moves according to formula (with data number 0 to 7)	0 - 160.0 mm	
16	Speed sensor 0 = Round sensor for roller 1 = Double sensor	0 1	1
17	Opening of inlet valve 0 = Quick opening 1 = Slow opening	0 1	0
18	Pressostat 0 = Inlet remains open at low pressure 1 = inlet closes at low pressure	0 1	0
19	Delay from stop sensor to turbine stopping (sec)	0	0

**MACHINE DATA**

40		0	0	2	Analog Pressure gauge 0 = Digital switch 1 = Analog pressure gauge – Display units [BAR] 2 = Analog pressure gauge – Display units [PSI]
41		0.50	0,10	5.00	Voltage Offset [V]
42		0.20	0,05	5.00	Voltage gain [V]
43		3,5	0,0	25,0	Pressure setpoint 0.0 –25.0 [BAR] Pressure level for Off – On
44		0.2	0.2	25.0	Pressure hysteresis 0.2 – 25.0 [BAR] Setpoint - 0.5* hysteresis for Off Setpoint + 0.5* hysteresis for On Default settings 0.2 <ul style="list-style-type: none"> <li>• 3.4 BAR = Off</li> <li>• 3.6 BAR = On</li> </ul>

**Program Rain can be set to 2 different types of sensors.**

See machine data no. 16 Sensor

One is a round sensor with 4 built-in sensors and can only be used for rollers with 1 magnet. When the battery is connected, the display shows the following for 2 seconds: **VERSION n.n0.**

The other is a rectangular sensor with 2 built-in sensors (double sensor). This is used for scanning on rollers with more than 1 magnet and for discs with from 1 to 20 magnets. When the battery is connected, the display shows the following for 2 seconds: **VERSION n.n1.**

**Cable connection**

Double sensor.			Round sensor		
<b>Program Rain 10 18 Pol Connector</b>			<b>Program Rain 10</b>		
<b>Cable connection</b>	<b>Version n.n1</b>	<b>Double sensor</b>	<b>Cable connection</b>	<b>Version n.n0</b>	<b>Round sensor</b>
1 + Battery	Brown	12 V	1 + Battery	Brown	12 V
2 - Battery	Blue		2 - Battery	Blue	
3 + Solar Panel	Brown		3 + Solar Panel	Brown	
4 - Solar Panel	Blue		4 - Solar Panel	Blue	
5 Motor 1	Speed Regulation		5 Motor 1	Speed Regulation	
6 Motor 1	Speed regulation		6 Motor 1	Speed regulation	
7 Speed Sensor 1 *	Blue		7 Speed Sensor	Blue	
8 Speed Sensor 1 *	Black		8 Speed Sensor *	Black	
9 Speed Sensor 2 *	Yellow/green		9 Speed Sensor *	Yellow/green (Red)	
10 Speed Sensor 2 *	Brown		10 Speed Sensor	Brown	
11 Stop Sensor	Blue or Brown		11 Stop Sensor	Blue or Brown	
12 Stop Sensor	Blue or Brown		12 Stop Sensor	Blue or Brown	
13 Motor 2		Stop Motor	13 Motor 2		Stop Motor
14 Motor 2		Stop Motor	14 Motor 2		Stop Motor
15 Pressure	Blue or Brown		15 Pressure	Blue or Brown	
16 Pressure	Blue or Brown		16 Pressure	Blue or Brown	
17 - BIP			17 BIP -		
Motor 3	Brown	Sprinkler	Motor 3	Brown	Sprinkler
18 + BIP			18 BIP +		
Motor 3	Blue	Sprinkler	Motor 3	Blue	Sprinkler
* If the distance counter count the wrong way, the speed sensor should be turned.			* If the distance counter count the wrong way, the cable on terminal 8 and 9 must be interchange.		
<b>Program Rain 10 6 Pol Connector</b>					
19 + GSM	Brown	+12 V			
20 - GSM (-Pressure)	Blue (Green)				
21					
22					
23 + Pressure	Brown	+12 V			
24 Pressure Signal	White	0-5V			

Technical data

Dimension (h\*w\*d) 170\*140\*100 [mm]  
 Voltage 10-15V DC  
 Current 6 mA (Rest) 30 mA (with GSM)  
 80 mA (with light)  
 5A motor max. current  
 Fuse 5A Fixed



**Troubleshooting:**

?

The turbine does not start when the **START** key is pressed.

Answer:

The magnet at the stop sensor is not in position or the sensor or sensor cable is damaged.

Stop sensor: The mark ■ must be on when the magnet is in position and off when the magnet is removed. See Menu 3.

A damaged cable can be assembled in an epoxy moulded assembly or with shrinkable tubing and glue.

However, since the sensors are more sensitive than telephone cables in the ground, cable assembly must be seen as an emergency solution.

If a pressostat is installed, the water must be pressurized. The mark ■ must be on when there is pressure.

?

No numbers in the display.

Answer:

Battery disconnected. Fuse inside the box may have blown. The fuse will blow if the battery is wrongly connected.

An additional fuse is available from the factory on a single fuse terminal on the circuit board.

Fuse 5A. Battery voltage 12V. See Menu 2.

?

Clock is set to 00:00

Answer:

If the power is interrupted, the clock is reset. The end time is then the number of hours and minutes until irrigation is complete.

See page 15 for setting the clock.

?

The number of metres is not counted correctly and the speed is not correct.

Answer:

If the speed is measured with a roller running on the hose, check whether the roller is running smoothly or if it is not installed properly on the hose.

You will also need to check that the roller sensor with cable is functioning properly. See Menu 3 Speed sensor.

The 2 marks ■ ■ must light up in the following order from the right during unwinding: The first one turns on, then the second one turns on, the first one turns off, then the second one turns off. During rewind, this happens in reverse order.

?

Only half or perhaps 2/3 of the actual length has been counted.

Answer:

The stop bracket with magnet for the stop sensor may have jumped, so the magnet has been removed temporarily from the stop sensor. This will reset the counter. Or a hose turn has been so loose that it has impacted the miswinding bracket.

This is usually the same as the impact on the stop bracket and has the same result.

Even if the metres are not saved in the memory, irrigation will still continue at the selected speed and the machine will stop as normal. However, there will be deviations if the speed is measured on a gear disc and the calculation is based on formulas entered in MACHINE DATA. This is because the electronics do not know which hose layer the machine is running on. Finally, the metres can be entered manually.

See page 21. CONSTANT no. 7

### Combining the various constants:

The machine will always be able to run with the factory-set constants. However, there will be different conditions from farm to farm and from machine to machine. Many requests can be met by changing the constants.

**1. Slow start-up of turbine. Set machine data no. 13 initially to approx. 2-4.**

This causes the speed regulator valve to close only about halfway, after which continued closing is performed in steps until the rewind speed reaches the set speed. The valve can then be fine-tuned to close first to the point where the turbine starts running and then to close in steps until the set speed is achieved.

**2. Slow opening of inlet. Set machine data no. 17 to 1.**

Opening for the water is then performed in steps.

**3. Only one motor for speed regulation, set machine data no. 12 to 0.**

Post-irrigation starts once the turbine stops, when the magnet at the stop sensor is affected. After the post-irrigation time has elapsed, the machine will restart and move to the mechanical stop.

**4. Start up no. 2 machine when no. 1 stops. Set machine data no. 12 to 0.**

With a pressostat installed on both machines, set the pressostats between the machine's operating pressure and the pump pressostat's stop pressure. For example, the operating pressure may be 6 bar and the pump stop 9 bar. Set the pressostats on the machines to 7.5 bar. No. 2 machine will then start up when the slow closing of the first machine reaches the point where the pressure in the ground line reaches 7.5 bar. Be aware that if the height difference of the fields is too great, the required pressure differentials that the pressostat must be set to may be too great.

**5. The machine should stop due to low pressure and with a pressostat installed. Set constant no. 6 to 1 and set machine data no. 12 to 2.**

This means that the stop valve opens instead of closing if the line connection to the stop valve is the same.

After 2 minutes, close it again, otherwise you will not be able to obtain pressure at start-up. When machine data 12 is set to 2, the valve can only be opened with the stop sensor, stop button and monitoring. But not when the pressostat is switched off.

## GSM-2G

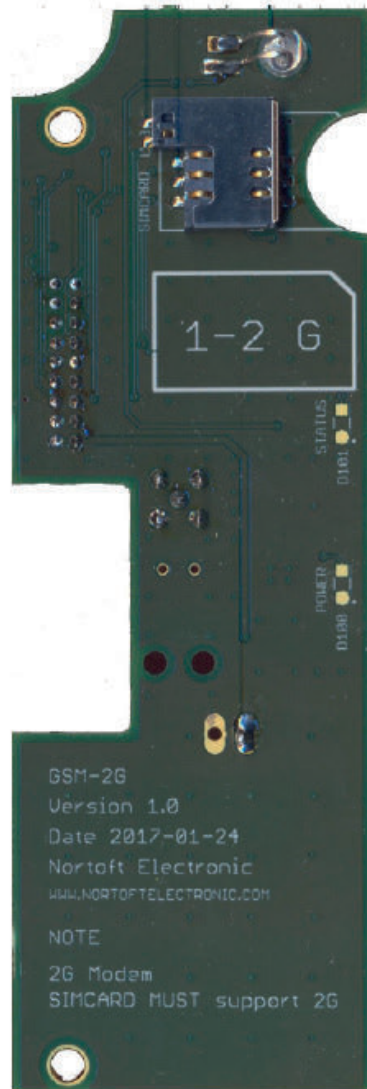

### Functions

Easy installation on PR10-12  
 Low power consumption  
 Total 10 mA consumption, PR10-12 and GSM-2G  
 Visible status LED

Supplied with  
 Antenna with 2 metre cable  
 Mounting accessories

### Modem

- Dual band 850/900/1800/1900 MHz
- GPRS multi slot class 12/10
- GPRS mobile station class B
- Compliant to GSM phase 2/2+
- Class 4 (2 W @850/900 MHz)
- Class 1 (1 W @1800/1900 MHz)
- Temperature range: -40 °C ~ 85 °C

## GSM

GSM-2G is a GSM modem made for PR10-12.

The machine can be started, stopped or queried about status by sending an SMS.

## Commands

<b>Start</b>	Starts the machine.
<b>Stop</b>	Stops the machine
<b>Speed ###</b>	Set the desired speed 3 to 400 m/h
<b>Status</b>	Returns the current machine status.

SMS can be written in small, large or mixed characters.

If you call the modem from a GSM phone, you will receive an SMS with **Status**

## Status

SPEED	30.0 m/h	SMS sent from machine contains miscellaneous information.
DOSE	22 mm	
TIME 14:10	STOP	18:16
STATUS IRRIGATING		
DISTANCE	123 m	
BATTERY	12.8 V	
CHARGER	ON	0.231 A

**SMS** is sent at:

<b>LOW PRESSURE:</b>	The machine has stopped due to a lack of water pressure.
<b>STOP SENSOR:</b>	The machine has reached the end and is ready for a new lane.
<b>STOP TELE:</b>	Machine is stopped via an <b>SMS</b> .
<b>STOP DIST:</b>	The machine has reached the stopping distance. (Constant 8)
<b>STOP MONITOR:</b>	Monitoring has stopped the machine. The machine has not moved for xx minutes. (See constant for monitoring).

## How to start the system:

Disconnect the battery from the electronics.

Insert the SIM card in a regular mobile phone and change the pin code to **1111**.  
Try sending and receiving an SMS to see whether the SIM and account work as intended.

**Note that SIM card *MUST* support 2G.** Some operators do not support 2G.

Install the modem using the supplied threaded rods.

Insert the SIM card in the modem device.

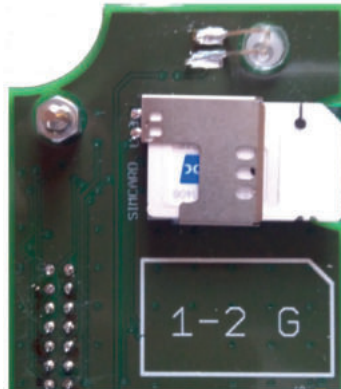

Connect the battery and set machine data #30

- = 0 No GSM
- = 1 Use GSM, all tele numbers can be used, no speed setting
- = 2 Use GSM, only the numbers created in the SMS list can be used.

<b>SPEED</b>	<b>11.1m/h</b>
<b>DOSE</b>	<b>22 mm</b>
<b>TIME</b>	<b>14:10 Stop 7:43</b>
<b>M.DATA</b>	<b>30 1</b>

See chapter for setting up data.

After approx. 30-45 seconds, the modem should be connected to the GSM network.

<b>SIGNAL 23</b>
<b>NETWORK HOME</b>
<b>A: +45123456</b>
<b>B: +45234567</b>

Signal strength, 0 - 31 and the network is then displayed in menu #6  
Signal strength of 10 or above is a stable connection.  
Signal strength of 99 indicates no signal.  
- Missing antenna  
- Very poor signal

**Modem has LED to indicate status.**

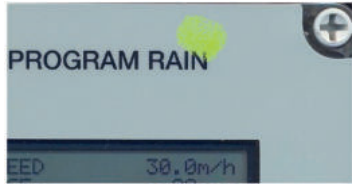

**Green**

Switched off

- Searching the network
- No SIM card in modem
- Incorrect PIN code
- No GSM network available

**LED**

Off

Flashes quickly

**STANDBY**

(Registered on network)

Flashes slowly

**Connection (TALKING)**

On

When an SMS is received, the display shows:

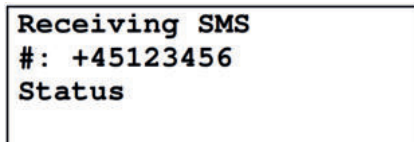

Receiving an SMS, sender's phone number and 40 characters of message. All SMS can be received, but only known commands are accepted.

When an SMS is sent, the display shows:

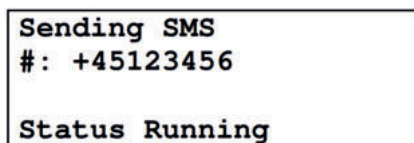

Sending an SMS, receiver's phone number and machine status.



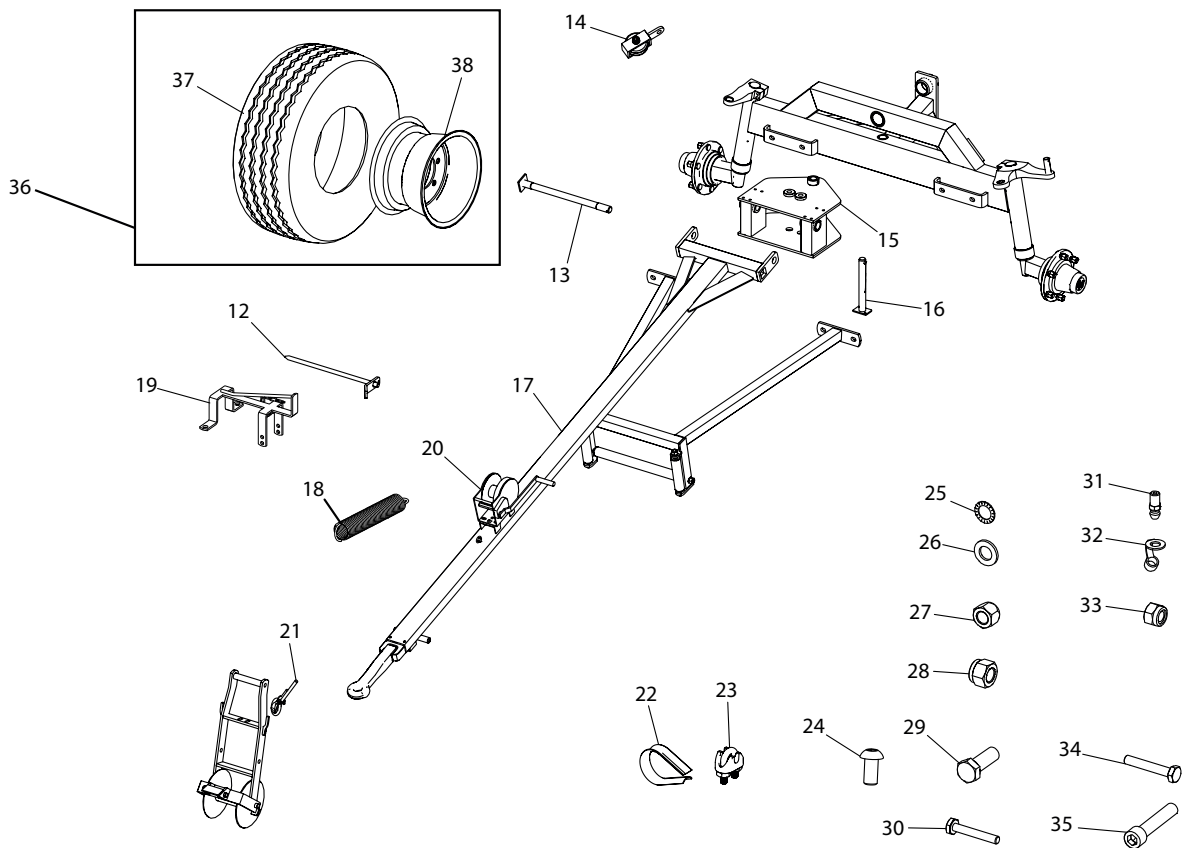
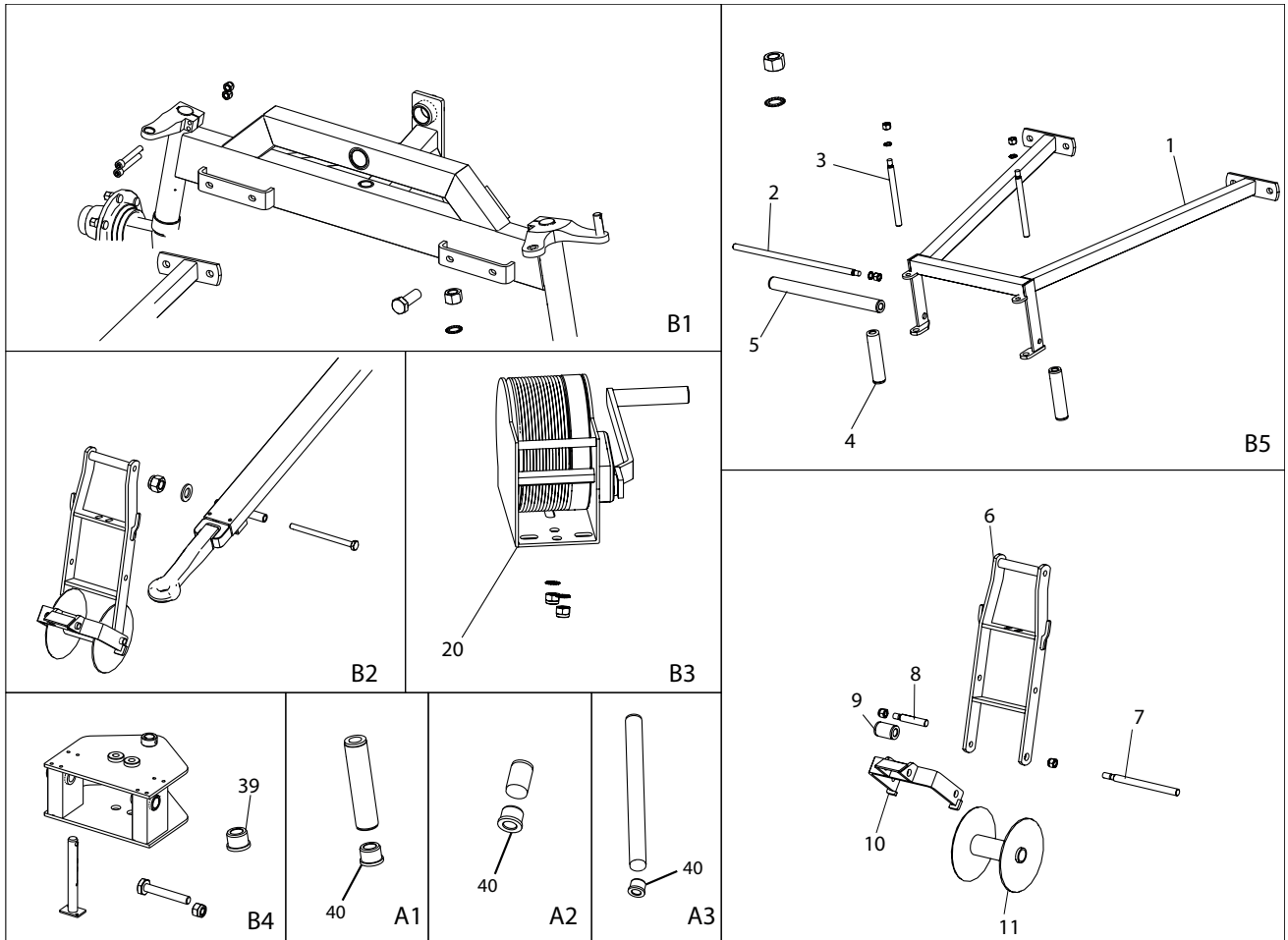



Item No.	Part No.	Qty	Description	Comments
1	1010107	1	Front hose guide	
2	1761026	1	Shaft Ø20x550	
3	761025	2	Shaft Ø20x245	
4	761023	2	Support roller 5/4 170 mm	A1
5	1761024	1	Support roller 5/4	A3
6	1008210	1	Bracket for steering wheel	
7	1008218	1	Shaft	
8	761273	1	Shaft 115 mm	
9	761272	1	Support roller 5/4 50mm	A2
10	1008215	1	Safety stop	
11	1008205	1	Steering wheel	
12	1001255	2	Ground spike	
13	1008222	1	Horizontal split pin	
14	761015-10	1	Cable roller	
15	1009170	1	Drawbar bracket	
16	1008220	1	Vertical split pin	
17	1008200	1	Drawbar	
18	1011011	1	Spring	
19	1761006	1	Wheel chock	
20	505500	1	Winch	
20	762036	1	Complete wheel with cable	
21	1010113	1	Cable Ø5 x 8500 mm	
22	761012-1	1	Cable thimbles	
23	761013-1	3	Cable lock	
24	095010020	2	M10 x 20 Round head	B3
25	763916	8	M16 Riplock	B1 & B5 & B2
26	050316	4	M16 Plain washer	B1
27	040416	7	M16 Steel nut	B1 & B5 & B2
28	044012	4	M12 Lock nut	B1
29	022216045	4	M16 x 45 Steel bolt	B1
30	021010065	1	M10 x 65 Steel set bolt	B4
31	761286	1	Lubrication nipple	
32	761286-2	1	Lubrication nipple Cap	
33	044010	3	M10 Lock nut	B3
34	021016230	1	M16 x 230 Steel set bolt	B2
35	030512085	4	M12 x 85 Int. hex	B1
36	1008750	1	Comp Wheel	
37	1008752	2	Wheel	
38	1008756	2	Rims	
39	1008226	2	Collar bushing	
40	761271	6	Nylon bearing for support roller	

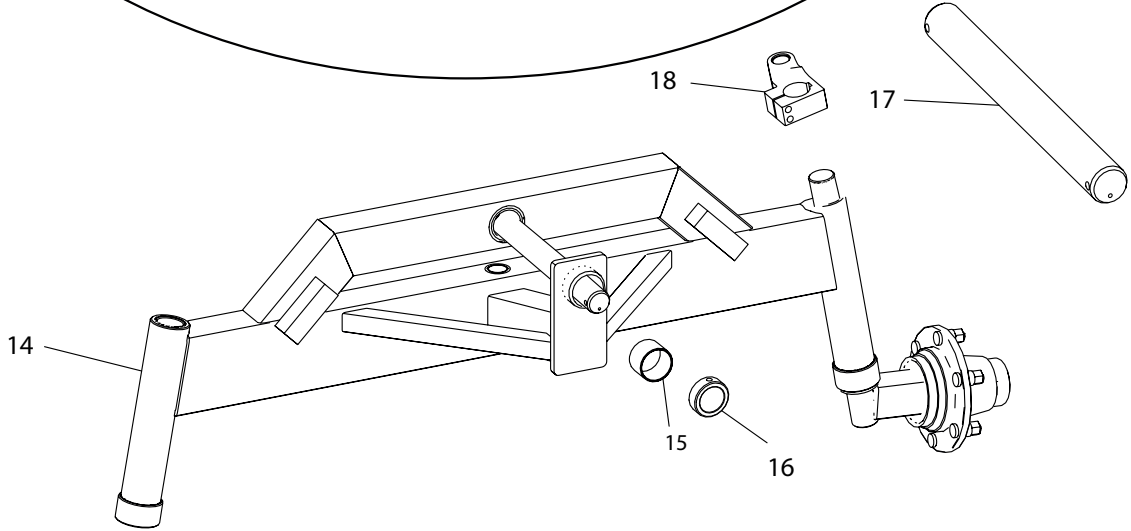
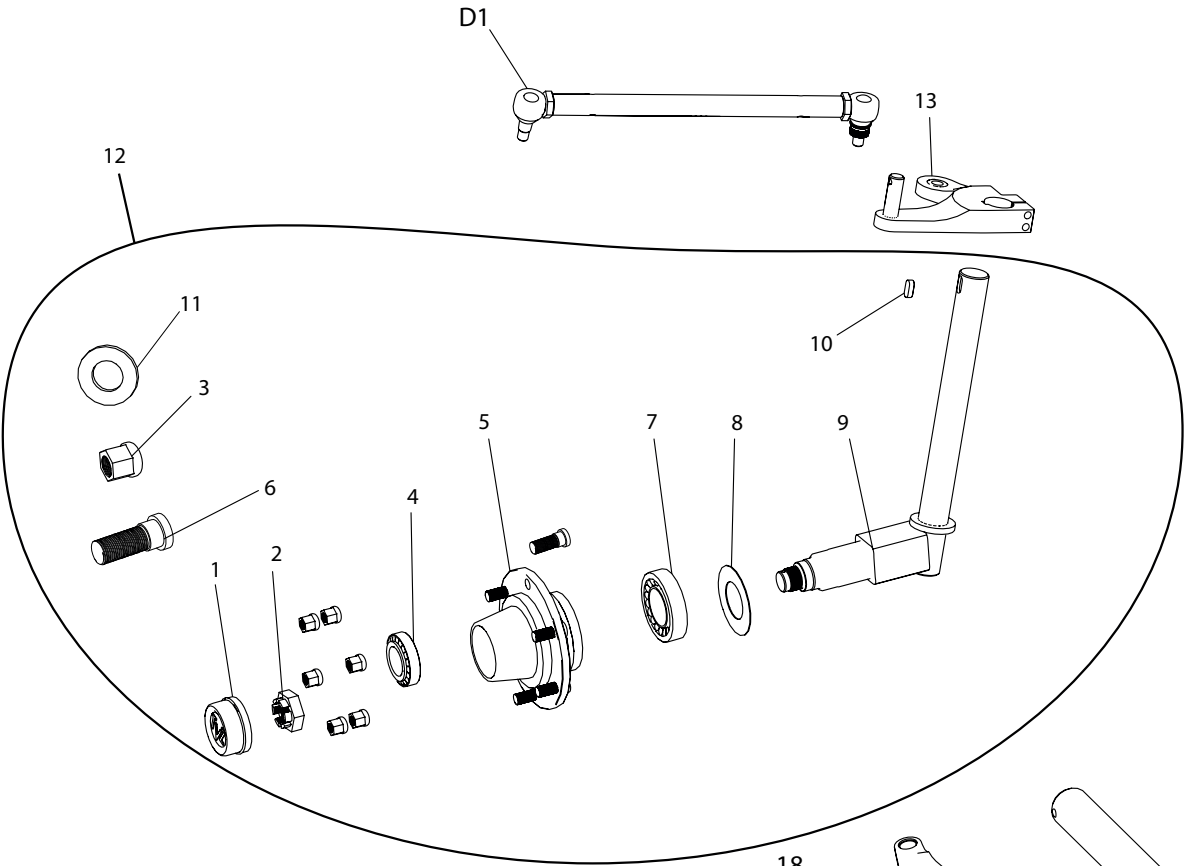
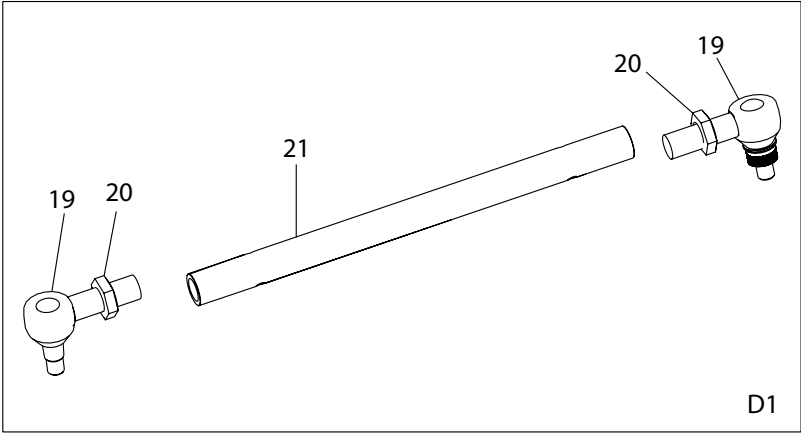

Item No.	Part No.	Qty	Description	Comments
1	1009181-6	2	Hub cap	
2	1009181-5	2	Crown nut	
3	1009181-4	12	Hub nut M18	
4	750032210	2	Tapered roller bearing	
5	1009181	2	Hub	
6	1009181-3	12	Hub bolt M18	
7	750032213	2	Tapered roller bearing	
8	1009181-7	2	Sealing washer	
9	1009185	2	Spindle	
10	1009188	2	Feather key	
11	1008198	5	Spacer washer for Shaft	
12	1009183	2	Spindle comp with Hub	
13	1009191	1	Spindle arm	
14	1009178	1	Front axle	
15	1008101	3	Bushing	
16	1008195	1	Stop ring	
17	1007629	1	Shaft for front axle	
18	1009192	1	Spindle arm Right	
19	1008155	4	Tie rod end	
20	1008157	4	Counter nut	
21	1009197	2	Control arm	

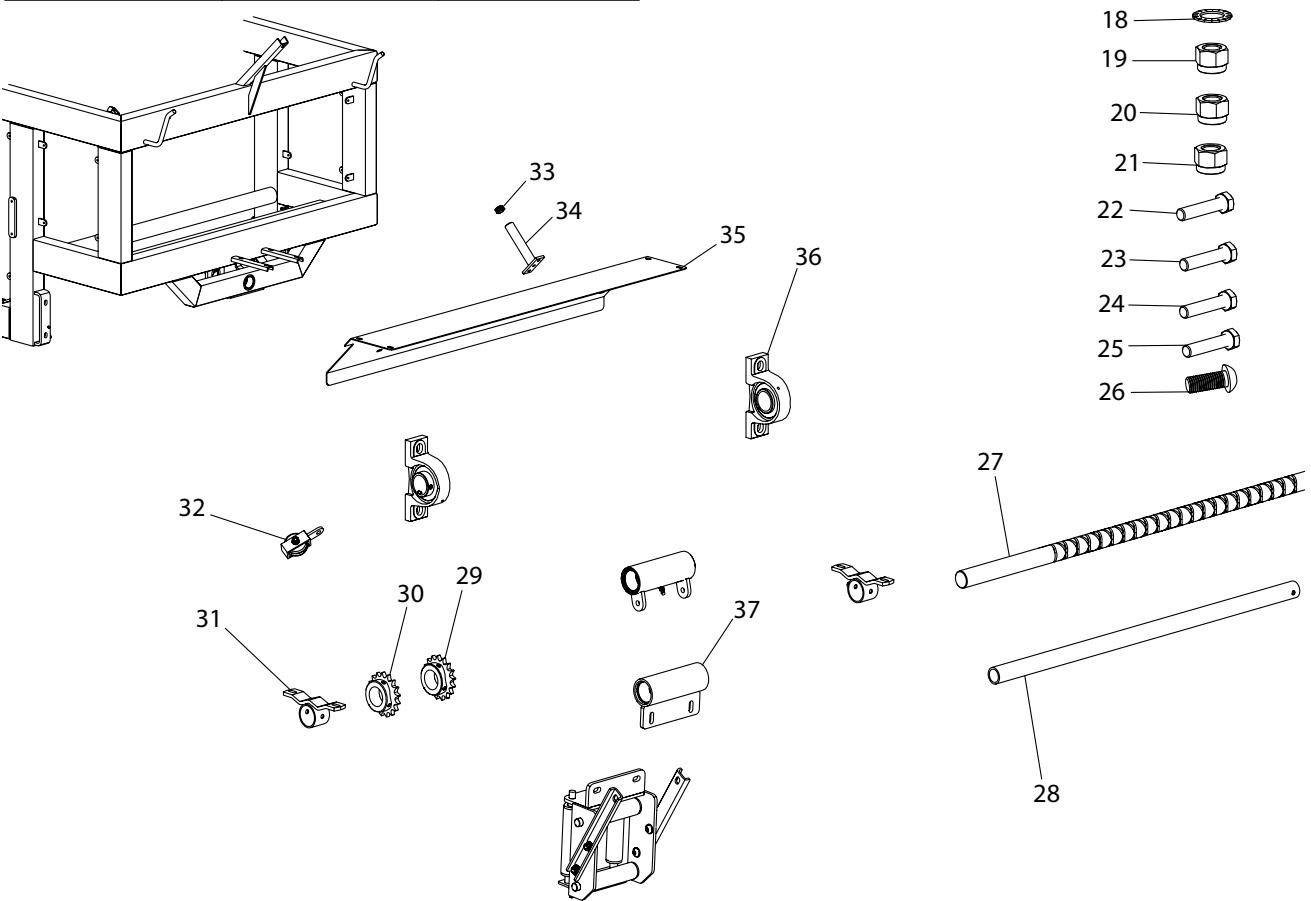
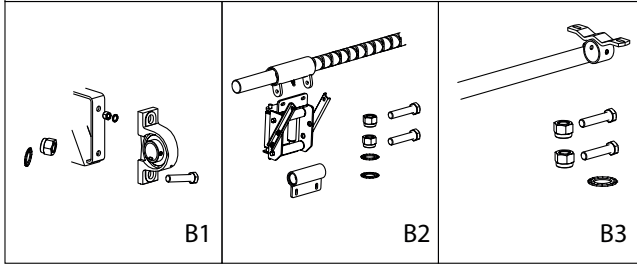
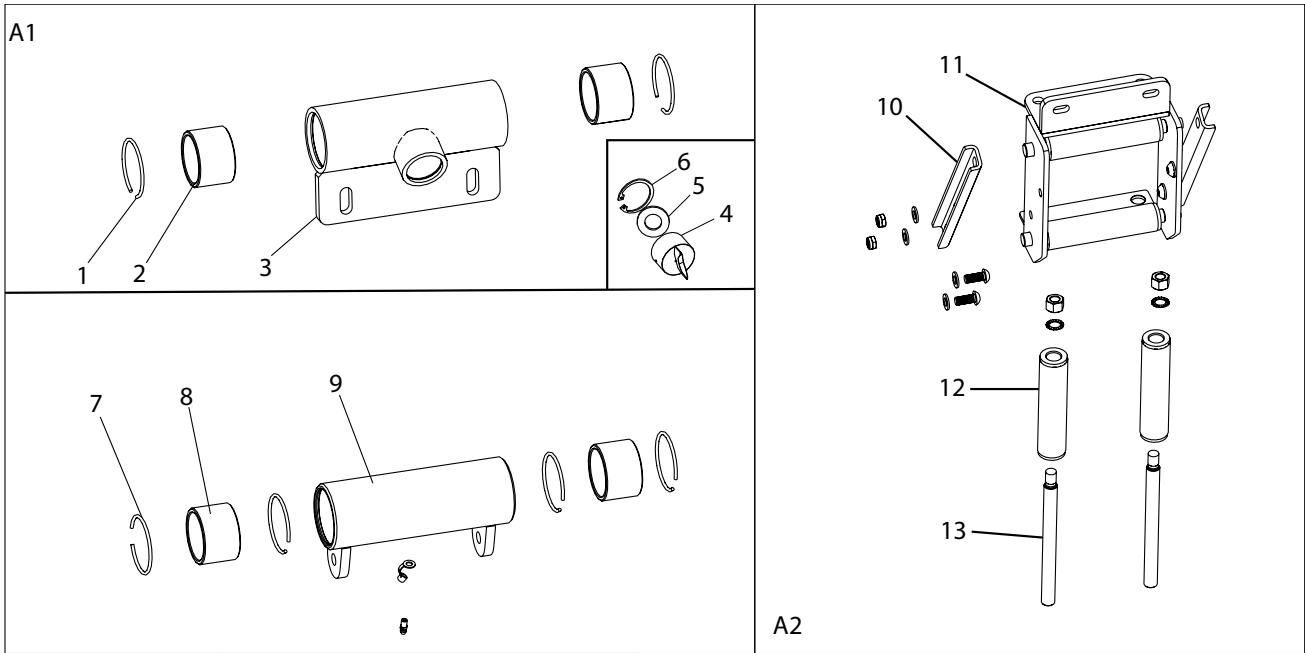

Item No.	Part No.	Qty	Description	Comments
1	1115100070-1	8	Spring ring 70 mm	A1
2	34000009	4	Bearing bushing for carriage	A1
3	1009875	1	Guide sleeve	
4	761283	1	Guide shaft (Pin)	
5	761284	1		
6	701042	1	Retaining ring	A1
7	761329	4	Retaining ring	
8	761293	4	Bushing	A1
9	1008475	1	Sleeve for support pipe carriage	
10	1008490	2	Brace for carriage	
11	1010090	1	Frame for carriage hose guides	
12	761023	4	Support roller with bearings	
13	761025	4	Shaft	
14	761286	1	Lubrication nipple	
15	761286-2	1	Cap for lubrication nipple	
16	050316	4	M16 Plain washer	B1
17	763916	8	M16 Riplock	B1 & A2
18	763912	4	M12 Riplock	A2 & B2 & B1 & B3
19	044010	1	M10 Lock nut	B3
20	044012	12	M12 Lock nut	A2 & B2
21	040416	8	M14 Steel nut	A2 & B1
22	021010075	1	M10 x 75 Steel bolt	B3
23	022216050	4	M16 x 50 Steel set bolt	B1
24	022212030	4	M12 x 30 Steel set bolt	B3
25	022212055	2	M12 x 55 Steel set bolt	B2
26	095012035	4	M12 x 35 Int. hex	A2
27	1010485	1	Cross spindle	
28	1010085	1	Support pipe for hose guide	
29	1001290	1	Sprocket 3/4	
30	1761290	1	Sprocket 3/4	
31	1008485	2	Holder for support pipe	
32	761015-10	1	Cable roller	
33	894955	2	Plug	
34	2003544	2	Hose stops	
35	1010130	1	Guard over hose guide shaft	
36	761289-1	2	Pillow block	
37	1009875-5	1	Comp guide sleeve	

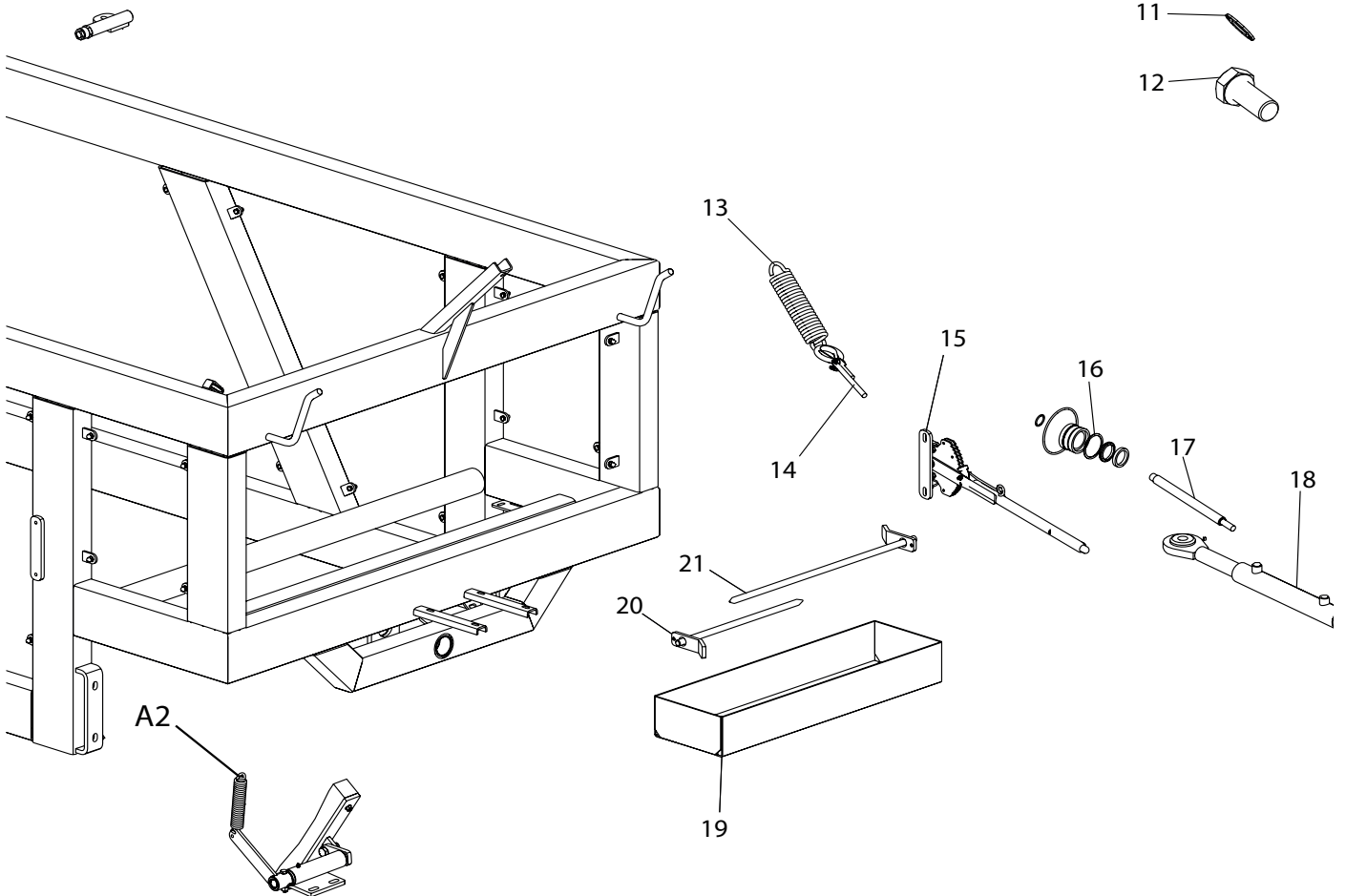
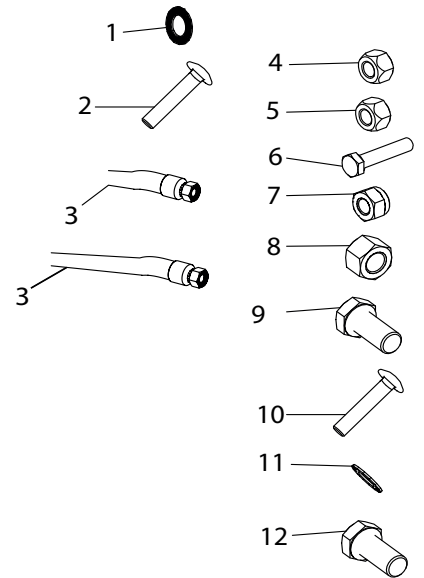
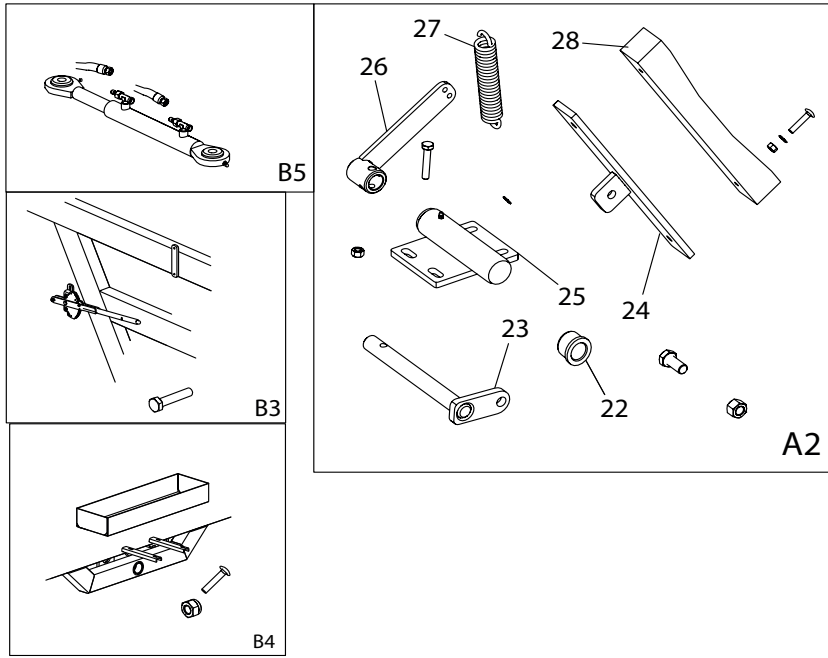

Item No.	Part No.	Qty	Description	Comments
1	050308	4	M6 Plain washer	B4
2	035206020	4	M6 x 20 Carriage bolt	B4
3	1010980	2	Hydraulic hose 7 m	B5
4	040408	2	M8 Steel nut	A2
5	044010	1	M10 Lock nut	A2
6	022208040	2	M8 x 40 Steel set bolt	A2
7	044016	1	M16 Lock nut	A2
8	044008	4	M6 Lock nut	B4
9	021010055	1	M10 x 55 Steel bolt	A2
10	763620	2	M8 x 40 Carriage bolt	A2
11	763908	4	M8 Riplock	A2
12	022216035	1	M16 x 35 Steel set bolt	A2
13	1008203	1	Drawbar spring	
14	1007803	1	Steel wire 3.5 m	
15	761113	1	Coupling lever	
16	1008585-1	1	Seal/gasket set	
17	1008585-2	1	Piston rod	
18	1008585	2	Cylinder	
19	1009341	1	Toolbox	
20	1001255	1	Ground spike 50 cm	
21	1010115	1	Ground spike 73cm	
22	1009337	2	Bushing for brake shaft	
23	1008355	1	Shaft for brake	
24	902119	1	Brake shoe	
25	1009335	1	Pipe for brake bushings	
26	1009275	1	Arm for brake	
27	761110	1	Spring	
28	902120	1	Brake block	

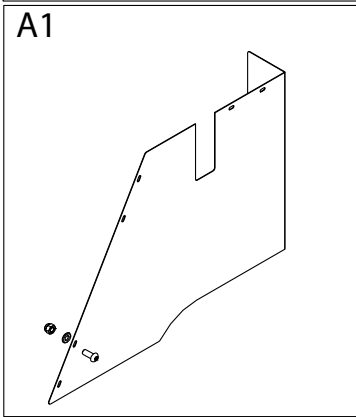
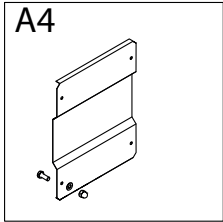
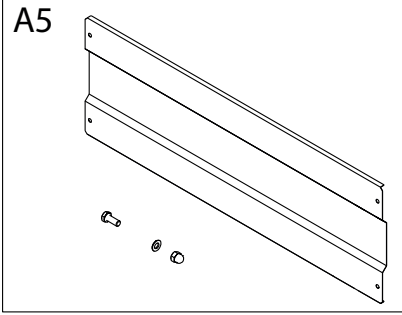
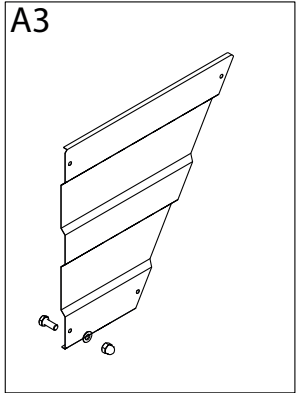
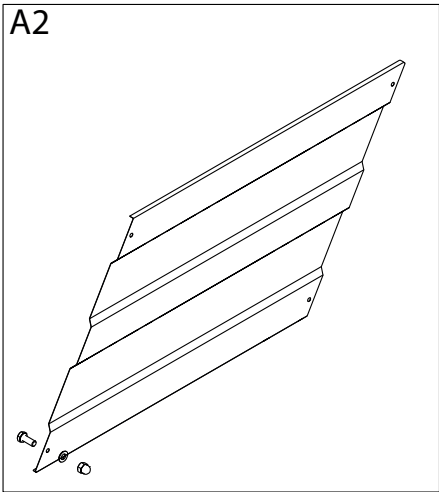

- 1
- 2
- 3
- 4
- 5
- 6

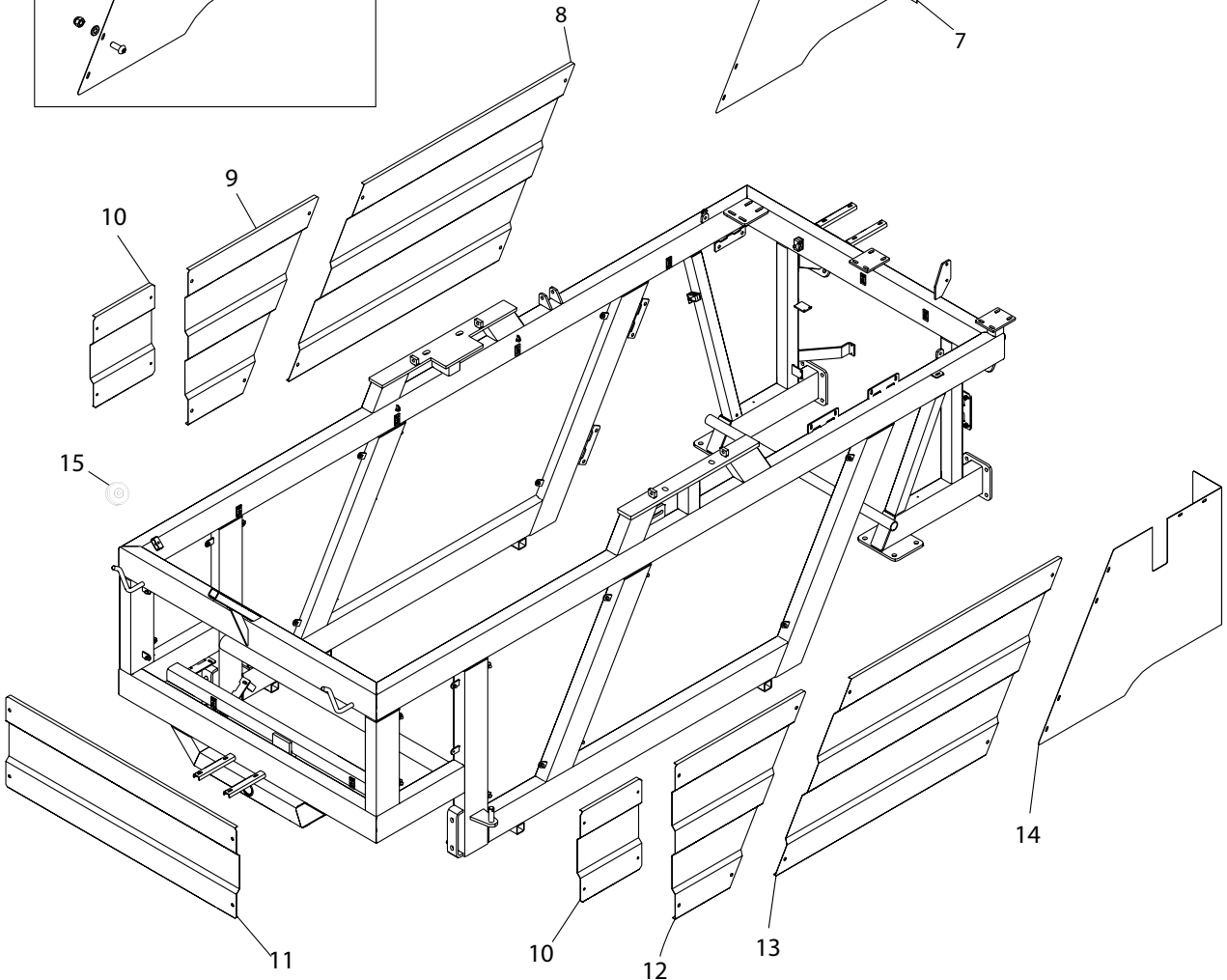
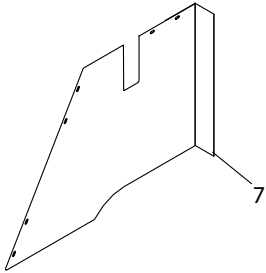



Item No.	Part No.	Qty	Description	Comments
1	022208020	32	M8 x 20 Steel set bolt	A2 & A3 & A5 & A4
2	763727	16	M10 x 25 Int. hex	A1
3	050208	32	M8 Plain washer	A1
4	050310	64	M10 Plain washer	A2 & A3 & A5 & A4
5	044010	8	M10 Lock nut	A1
6	763930	32	M8 Cap nut	A2 & A3 & A5 & A4
7	1010501	1	Inner guard rear wheel right	
8	1010503	1	Angled side guard large right	
9	1010536	1	Angled side guard small right	
10	1010540	2	Side guard	
11	1010550	1	Name plate	
12	1010535	1	Angled side guard small left	
13	1010502	1	Angled side guard large left	
14	1010500	1	Inner guard rear wheel left	
15	761015-15	2	Cable roller loose	

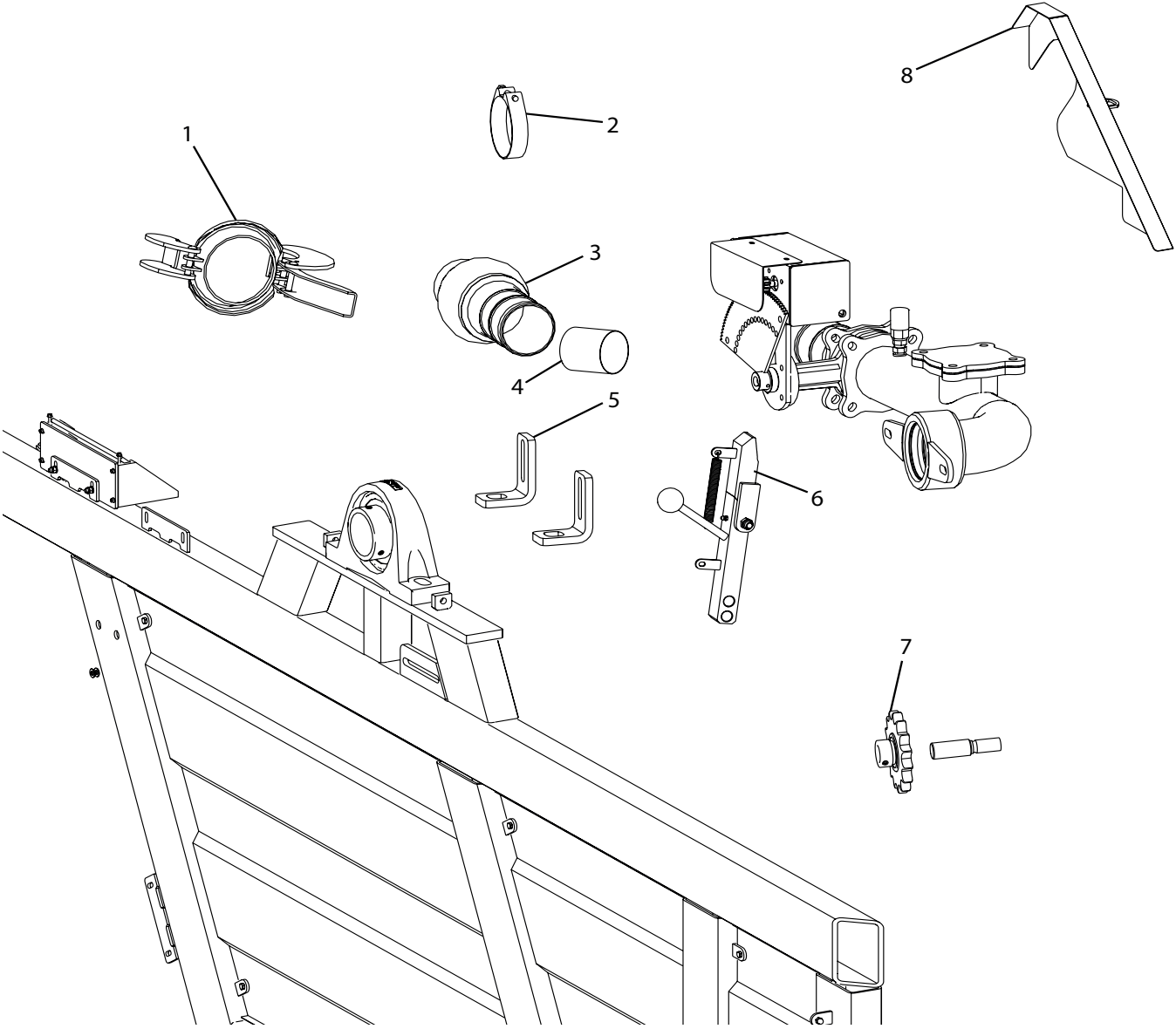
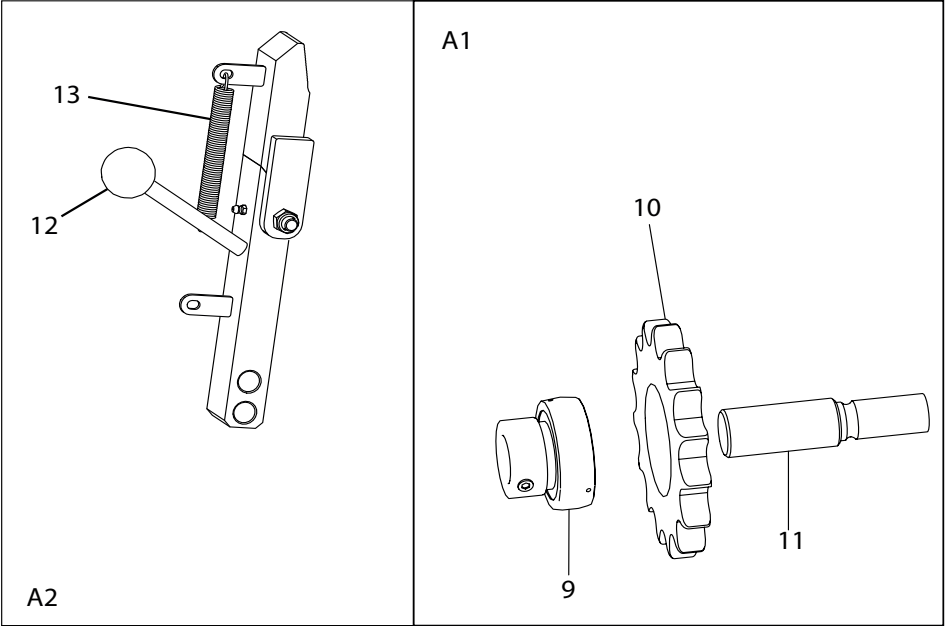

Item No.	Part No.	Qty	Description	Comments
1	14050013	1	Locking ring	
2	16200726	2	Hose clamp	
3	1009290	1	HK Ball with hose connector	
4	16050210	1	Soft hose no. per running metre	930 mm
5	1001087	4	Angle bracket	
6	1008260	1	Locking pawl	
7	2351278	1	Sprocket	
8	1010559	1	Chain guard	
9	761276	1	Bearing	
10	311215	1	Sprocket	
11	761275	1	Shaft	
12	763300	1	Ball lever	
13	570114	1	Drawbar spring	

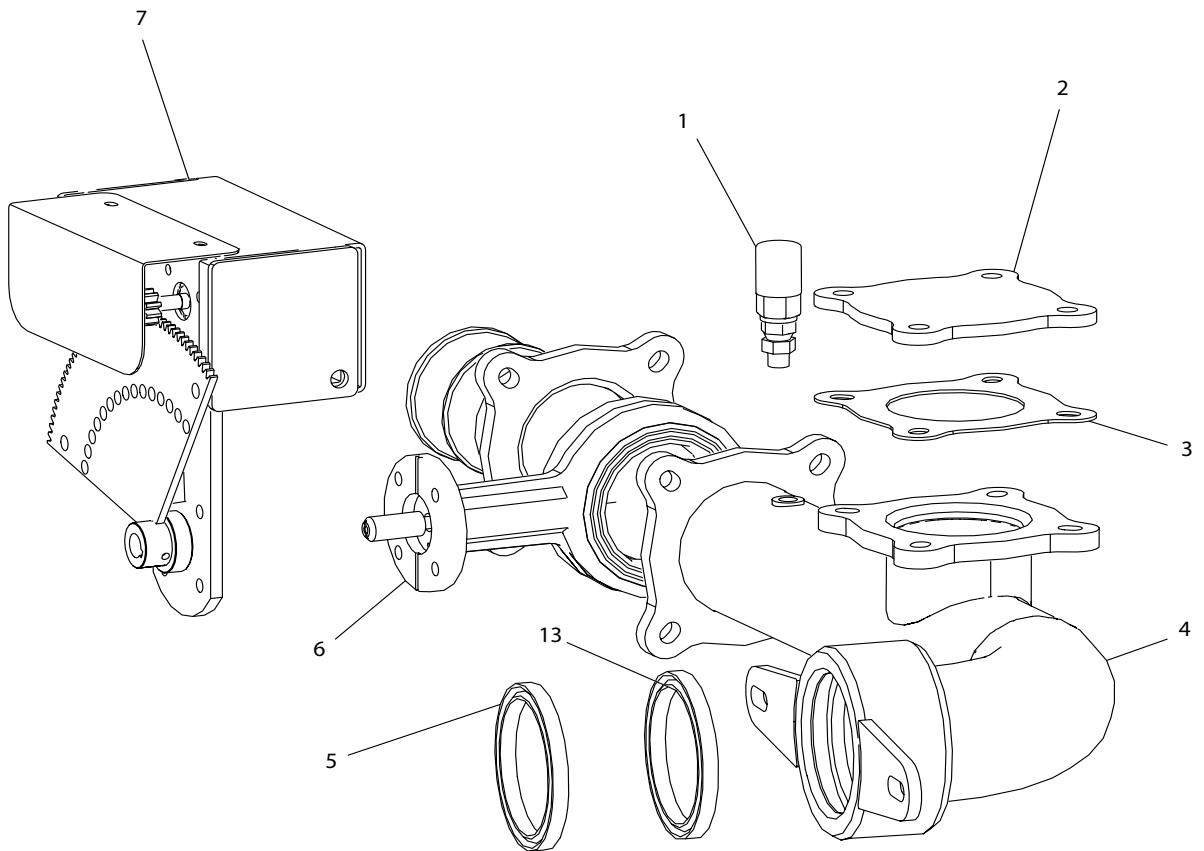
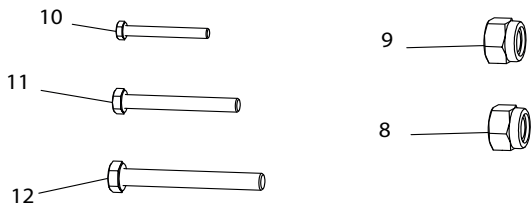
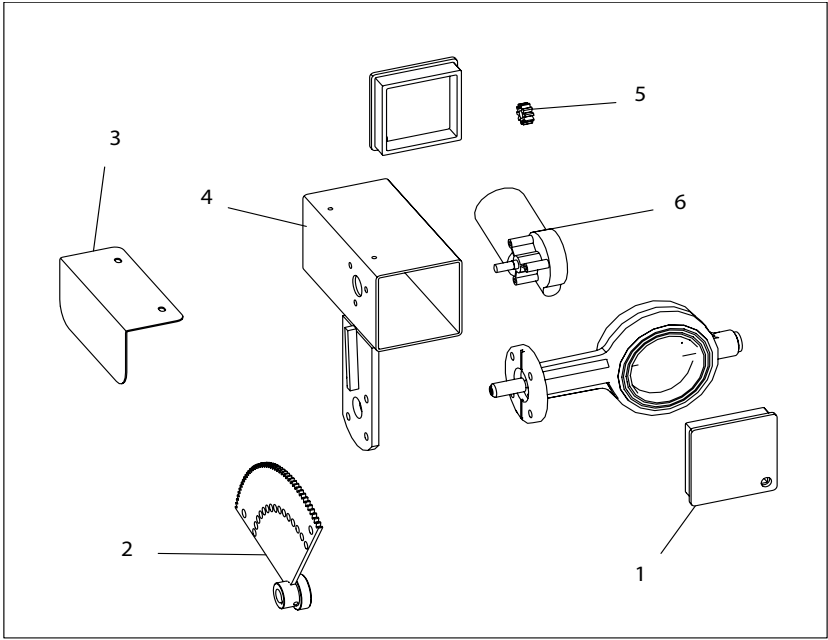

Item No.	Part No.	Qty	Description	Comments
1	1007545	1	Pressostat	
2	1007098	1	Blind flange	
3	631112	1	Flange gasket	
4	1009295	1	Head with pipe and flange	
5	1001095	1	Sealing ring	
6	1007250	1	Butterfly valve	
7	1007230	1	Comp motor valve	
8	044008	4	M8 Lock nut	
9	044010	8	M10 Lock nut	
10	021008035	4	M8 x 35 Steel bolt	
11	022210040	4	M10 x 40 Steel set bolt	
12	021010085	4	M10 x 85 Steel bolt	
13	1102138	1	Sealing ring	

## Parts list 1007230

Item No.	Part No.	Qty	Description	Comments
1	1007175	2	End plug	
2	1007195	1	Gear for valve	
3	1007185	1	Guard for motor valve	
4	1007171	1	Motor housing	
5	1007190	1	Gear for motor	
6	1007180	1	Motor	

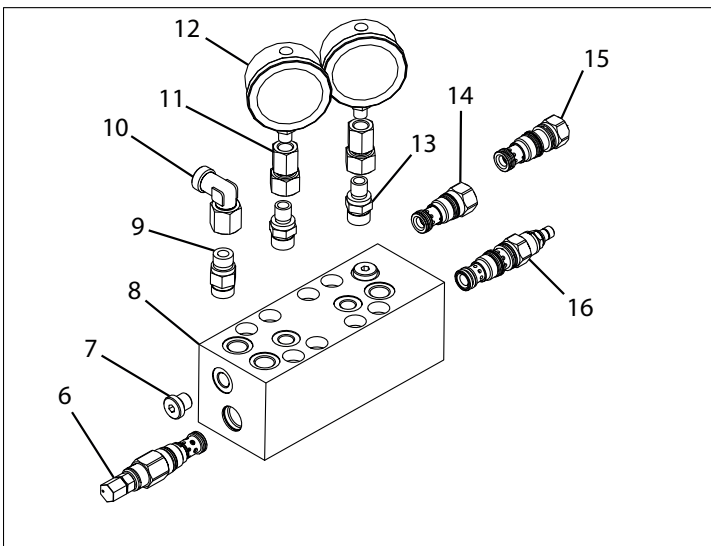
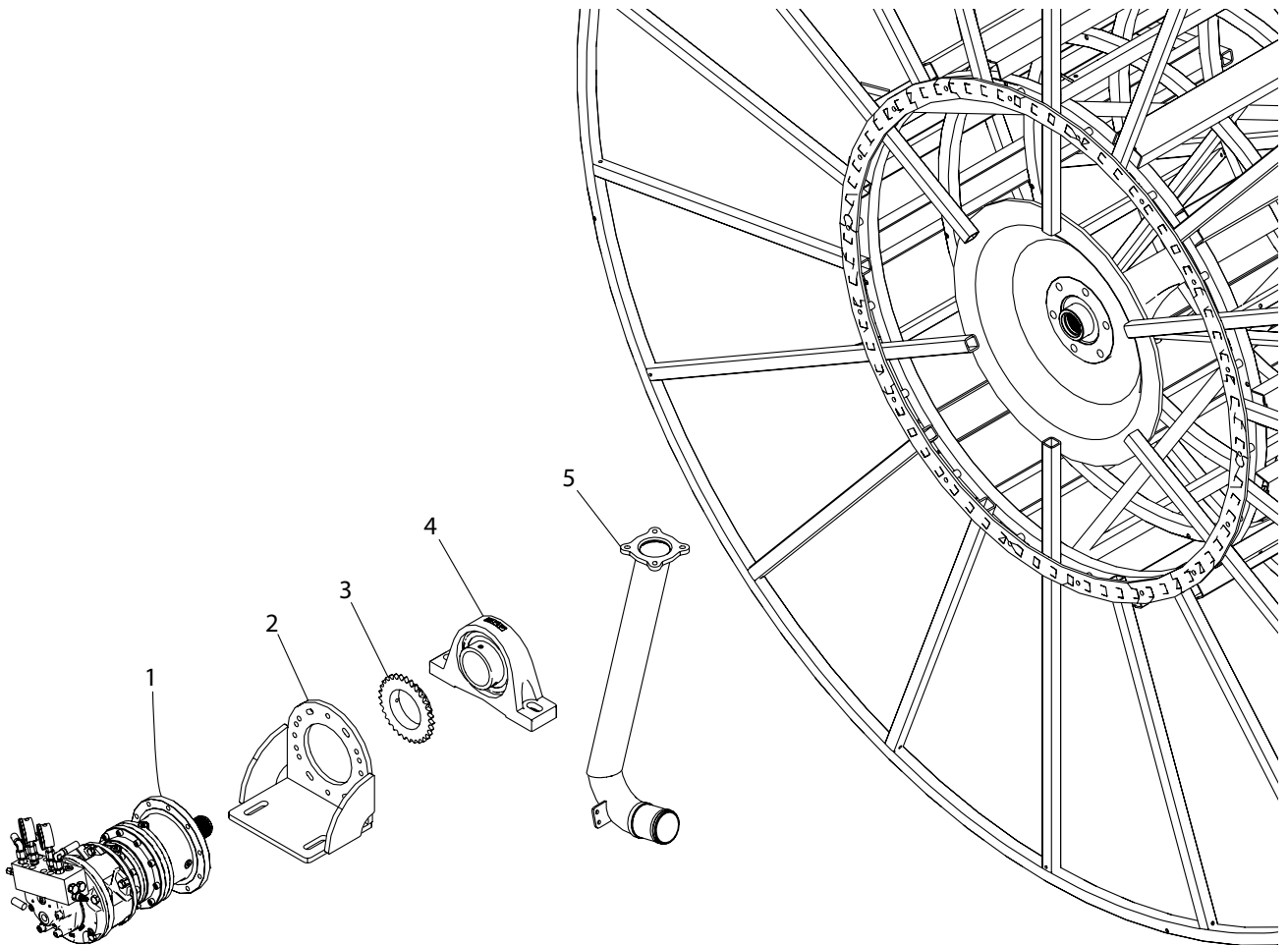

Item No.	Part No.	Qty	Description	Comments
1	1013900	1	Drive set	
2	1010700	1	Bracket for hose drum drive	
3	1009726	1	Sprocket	
4	1010490-2	2	Bearing	
5	2003355	1	Inlet pipe for hose drum	Ø110
6	1013965	1	Back pressure valve 5 bar	
7	1010972	1	Plug	
8	1013940	1	Alu block	
9	1007724	1	Nipple straight 3/8 x Ø12 mm disc	
10	1008622	1	Angle with fixed mounting	
11	1010979	2	Nipple straight for manometer	
12	761163-4	2	Manometer 0-100 bar x 1/4 RG	
13	1010978	2	Nipple straight 1/4 x Ø12	
14	1013943	1	Pilot controlled check valve	
15	1013948	1	Check valve for drum roller	
16	1013942	1	3-way Pressure reduction valve	

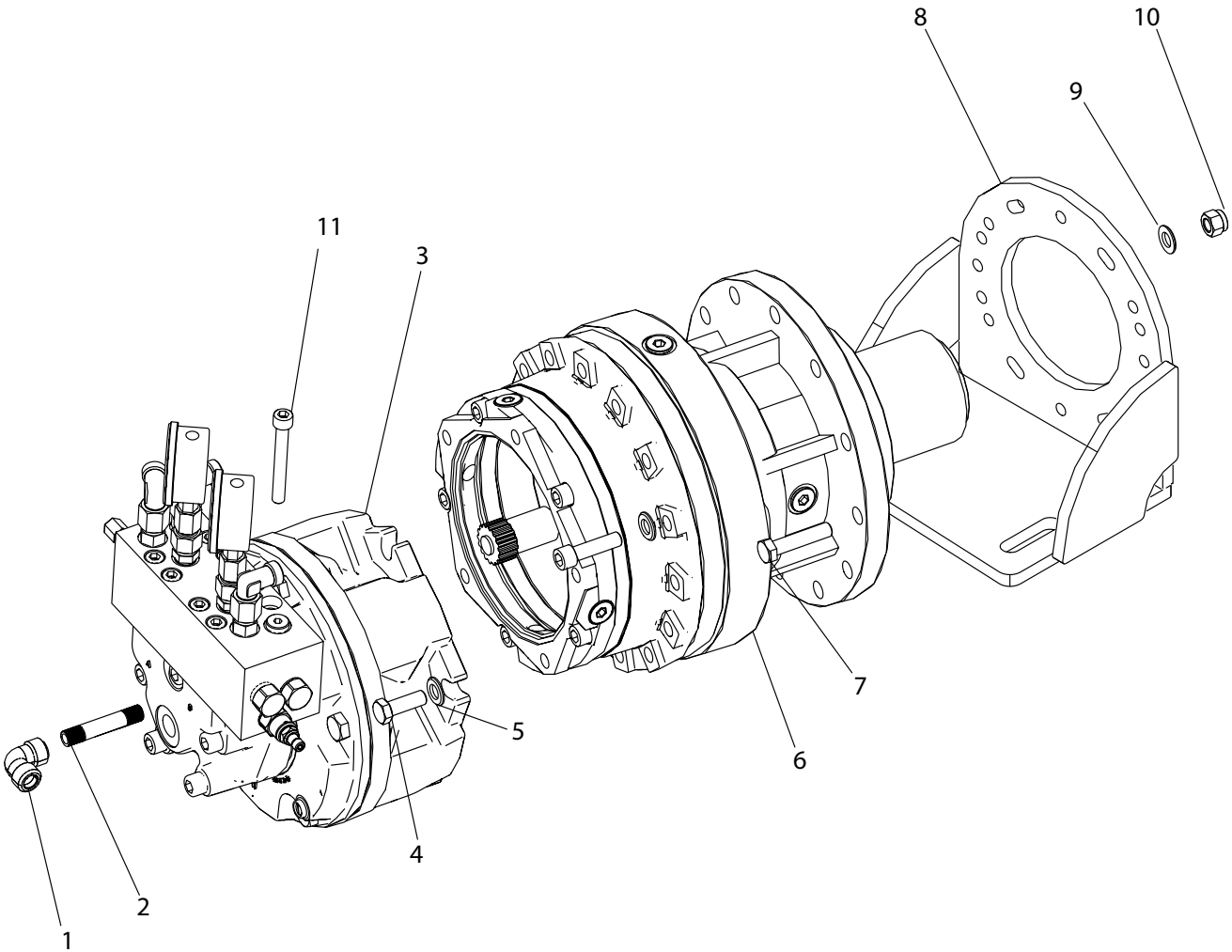



Item No.	Part No.	Qty	Description	Comments
1	000090402	1	Angle 1/4	
2	012120402	1	Nipple pipe 1/4	
3	1013930	1	Piston motor	
4	030512130	5	M12 x 130 int. hex	
5	056212	5	Spring washer	
6	1013910	1	Gear for piston motor	
7	021012050	10	M12 x 50 Steel bolt	
8	1010700	1	Bracket for hose drum drive	
9	763912	20	M12 Riplock	
10	040412	10	M12 Steel nut	
11	030010080	8	M10 x 80 round with int. hex	

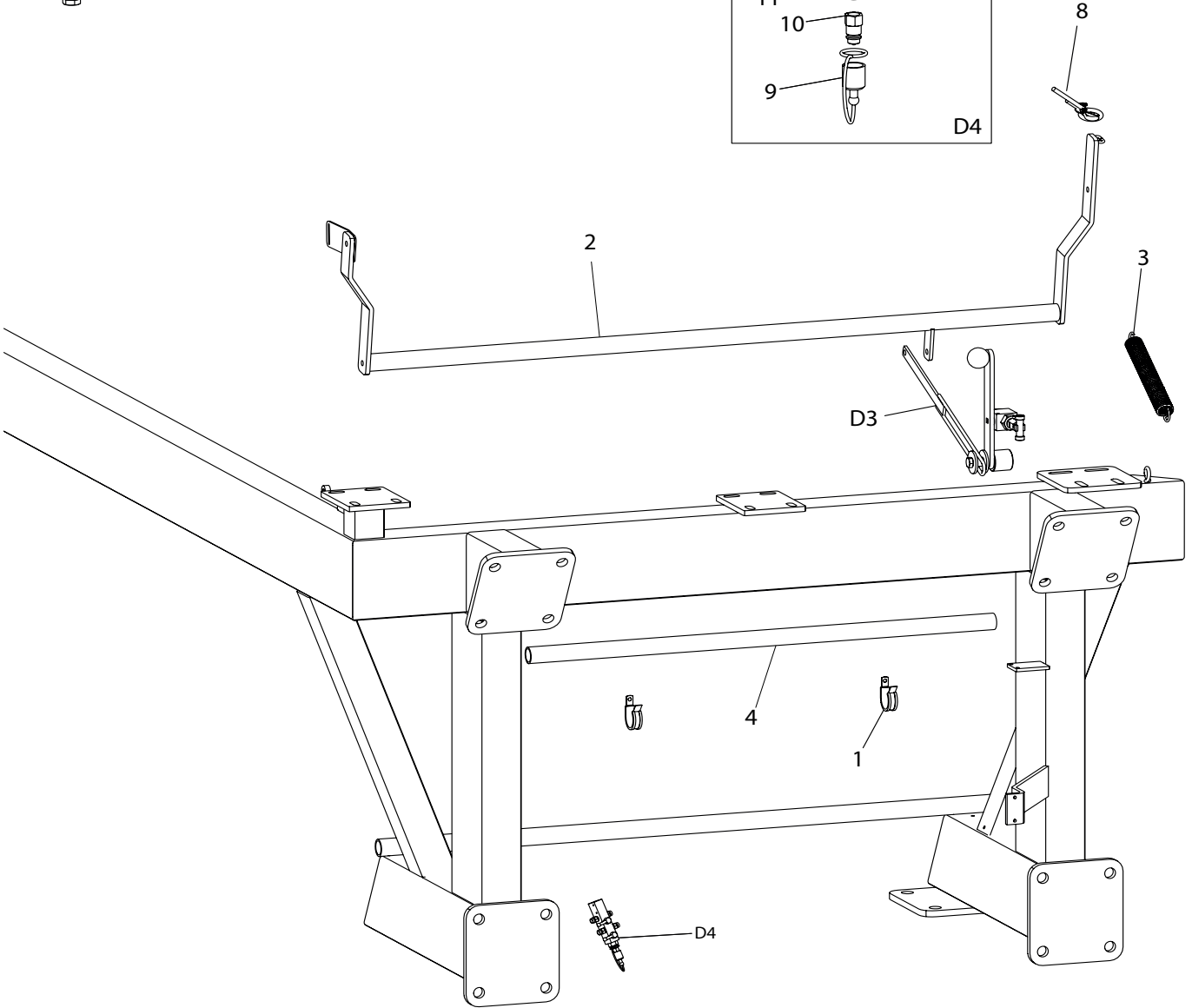
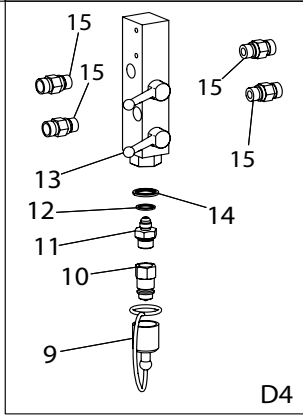
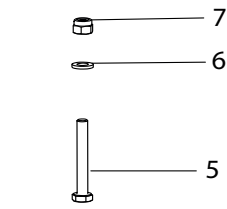
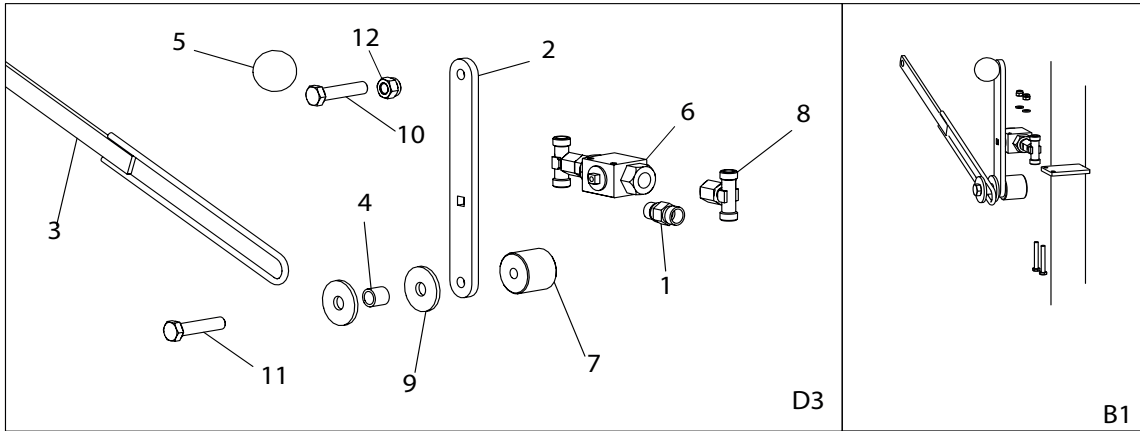

Item No.	Part No.	Qty	Description	Comments
1	1007770	1	Pipe bracket	
2	2008508	1	Miswinder	
3	761274	1	Spring	
4	1009660	1	Plastic pipe for cables	
5	022206045	2	M6 x 45 Steel set bolt	B1
6	051006	2	M6 Plain washer	B1
7	044006	2	M6 Lock nut	B1
8	1010113	1	Cable Ø5 x 8500 mm	
9	801711	1	Plastic plug	
10	801710	1	Oil coupling	
11	1007538	1	Nipple straight 1/2 x 3/8	
12	552025	1	Sealing ring	
13	BS20	1	Ø20 mm Gasket	
14	1010755	1	2-way ball valve	
15	1007724	4	Nipple straight 3/8	

## Parts list for D3

Item No.	Part No.	Qty	Description	Comments
1	1007724	2	Nipple	
2	1008335-1	1	Lever for ball valve	
3	1009260	1	Stop bar	
4	109101	1	Spacer	
5	763300	1	Ball lever	
6	1007510	1	Ball valve	
7	1007511	1	Wheel chock	
8	1007518	2	Tee	
9	05401250	2	M12 Round washer	
10	022212035	1	M12 x 35 Steel set bolt	
11	022212055	1	M12 x 55 Steel set bolt	
12	040412	2	M12 Steel nut	

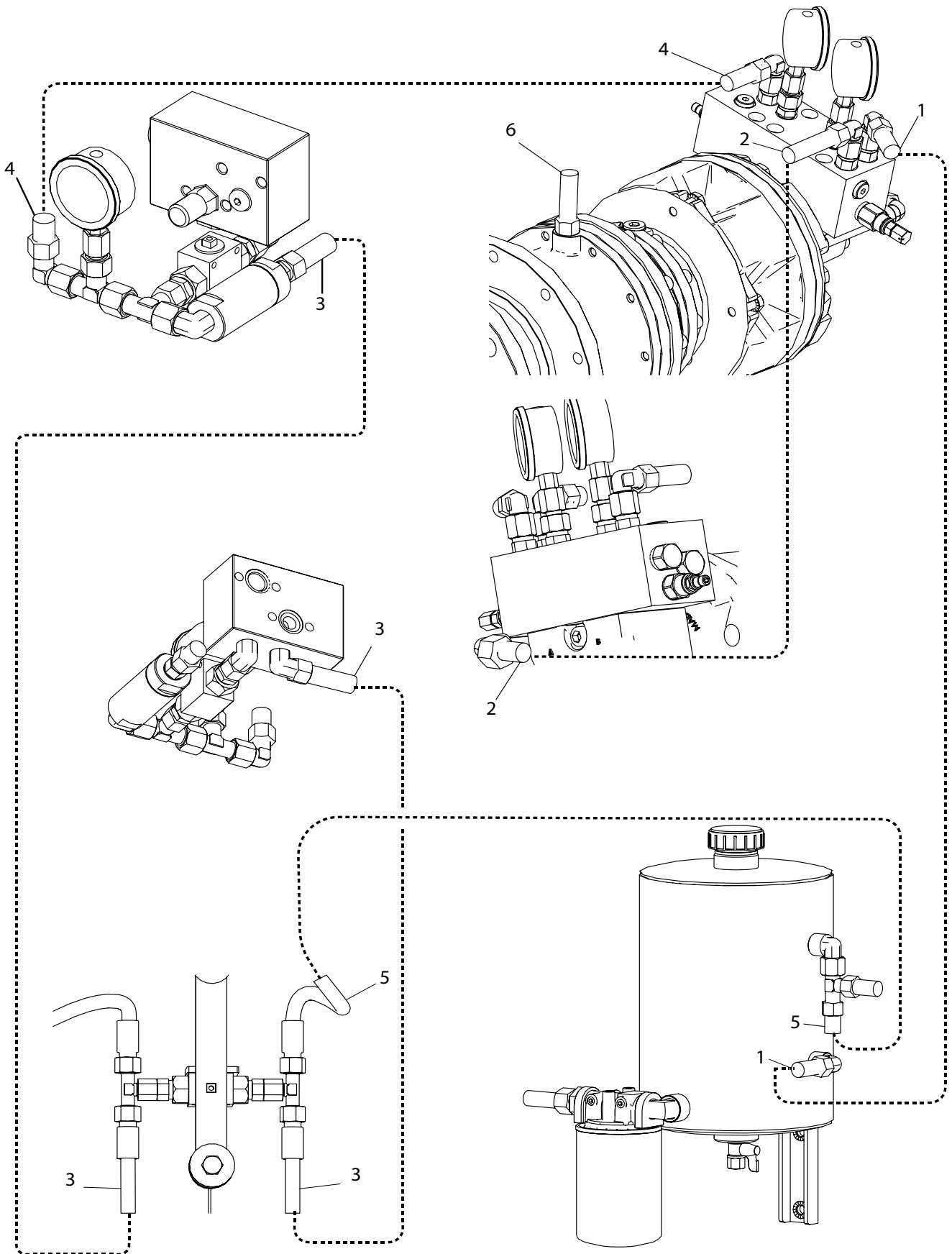

Side 1-2

Item No.	Part No.	Qty	Description	Comments
1	1010988	1	Hose 3/8 x 3600 mm	
2	1008612	1	Hose 3/8 x 600 mm	
3	1008601	2	Hose 3/8 x 1600 mm	
4	1008614	1	Hose 3/8 x 4900 mm	
5	1008609	1	Hose 3/8 x 1200 mm	
6	1010981	1	Hose 1/4 x 1230 mm	

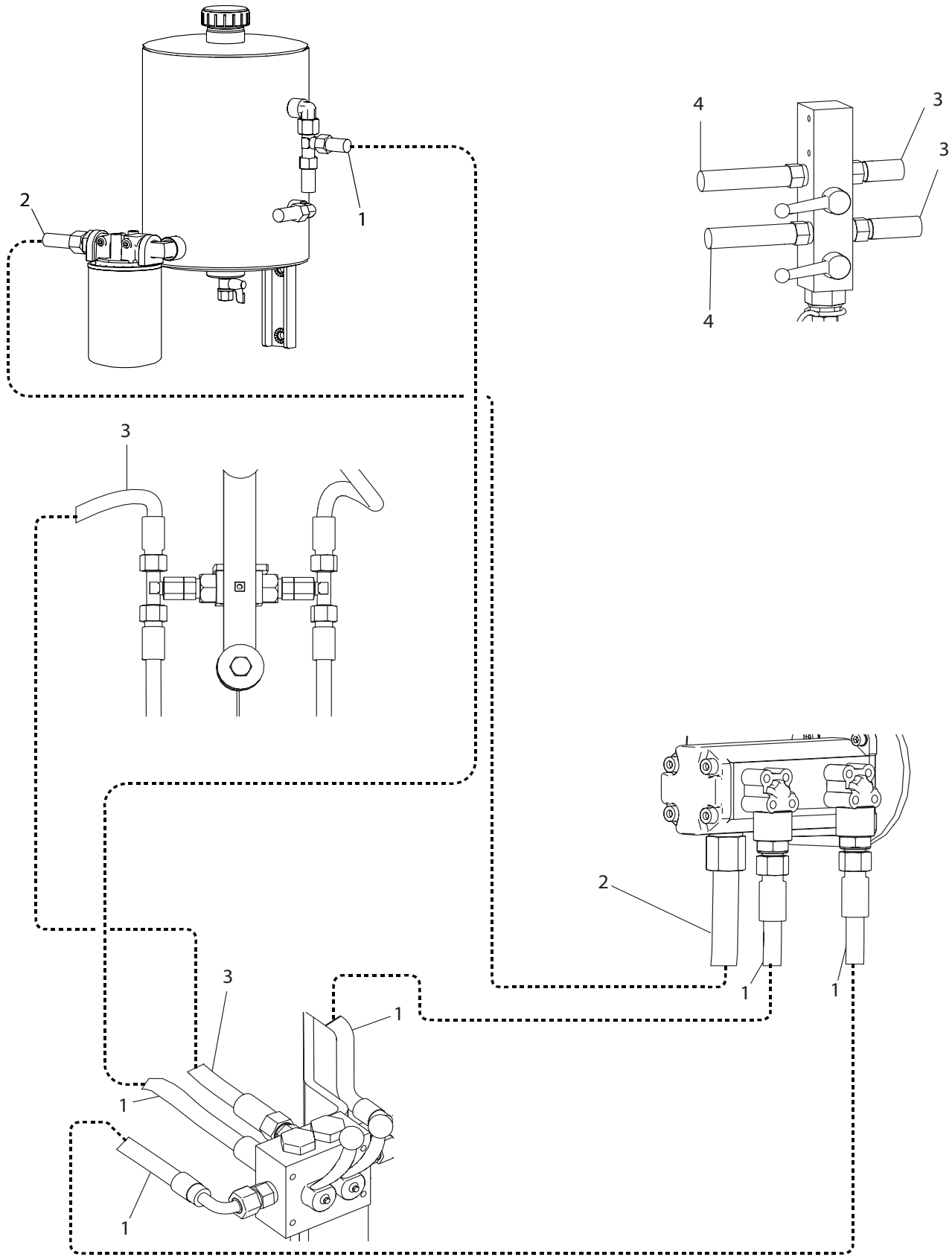

Side 2-2

Item No.	Part No.	Qty	Description	Comments
1	1008601	3	Hose 3/8 x 1600 mm	
2	1008605	1	Hose 1/2 x 750 mm	
3	1008600	3	Hose 3/8 x 1050 mm	
4	1010980	2	Hose 3/8 x 7000 mm	

FLADGEAR

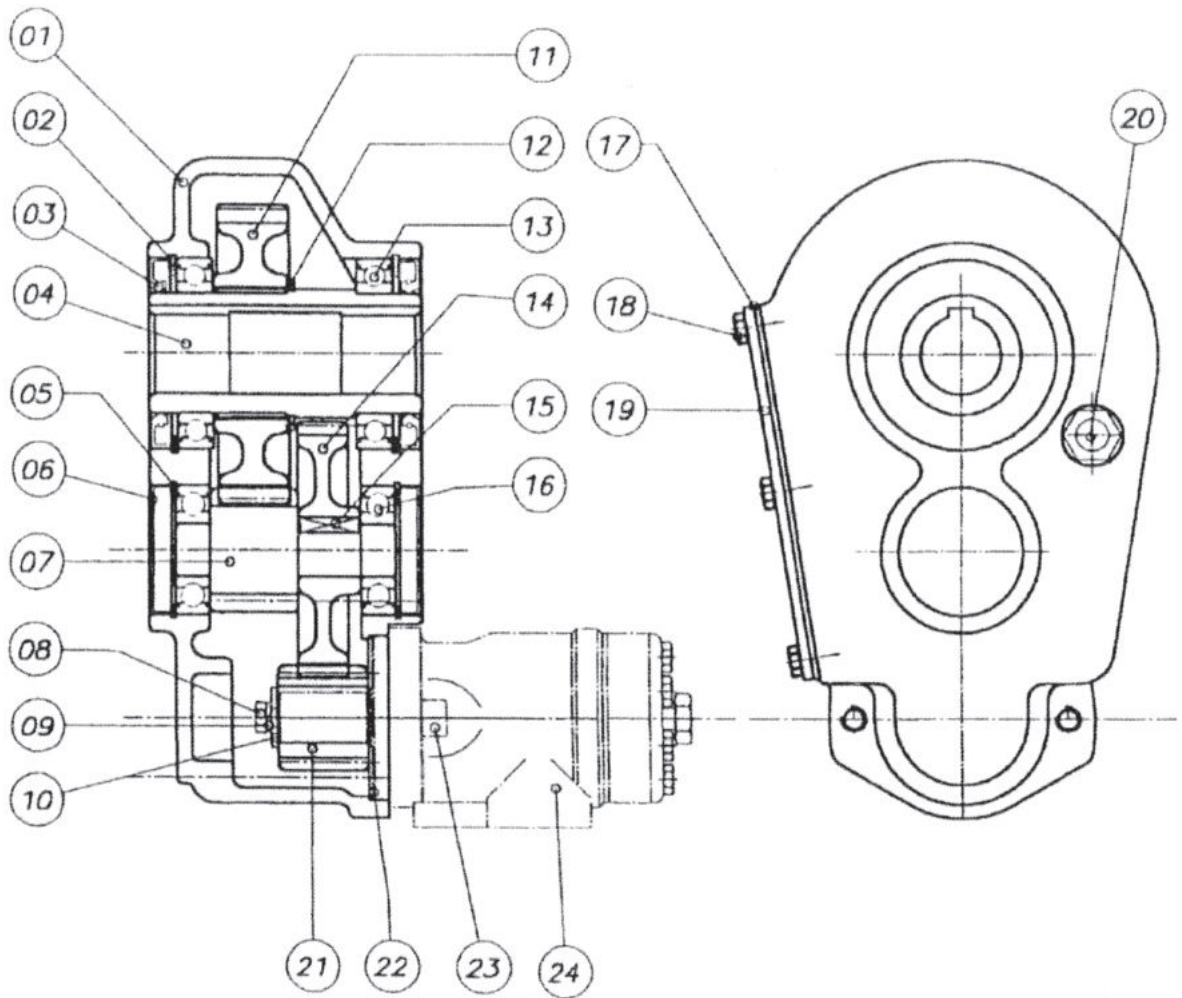



Item No.	Part No.	Qty	Description	Comments
1	1009500	1	Gear comp	
2	1009504	1	Retaining ring 95 mm	
3	1009505	1	Sealing ring Ø60/95x10	
4	1009506	1	Hollow shaft Ø40	
5	1009507	1	Retaining ring 62mm	
6	1009508	1	Cover Ø62	
7	1009509	1	Shaft/Gear	
8	1009510	1	Bolt with int. Hex M8 x 20	
9	1009511	1	Washer	
10	1009512	1	Spring washer	
11	1009513	1	Gear	
12	1009514	1	Retaining ring 65mm	
13	1009515	1	Bearing	
14	1009516	1	Gear	
15	1009517	1	Key	8 x 7 x 30
16	1009518	1	Bearing	6305
17	1009519	1	Flange gasket	
18	1009520	1	M8 x 16 mm	
19	1009521	1	Cover	
20	1009522	1	Sight glass	1/2
21	1009523	1	Gear	
22	1009524	1	Gasket	
23	1009529	1	Int. hex M12 x 35	
24	1007440	1	Oil motor	

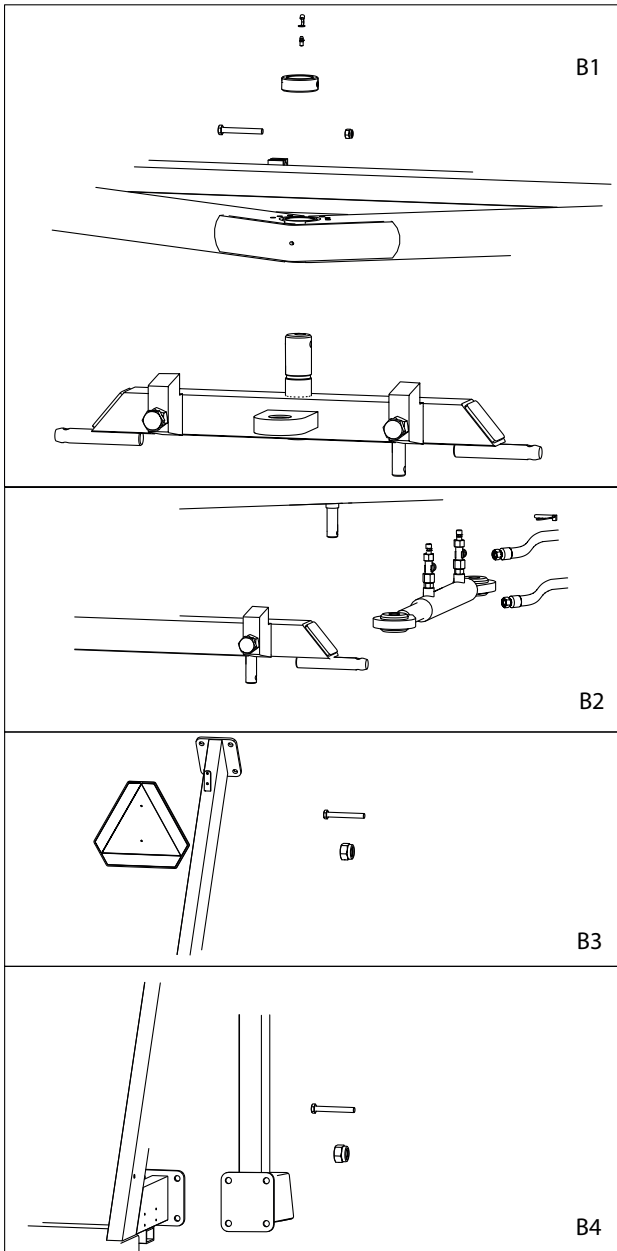

- 11 —
- 12 —
- 13 —
- 14 —
- 15 —
- 16 —
- 17 —
- 18 —
- 19 —
- 20 —

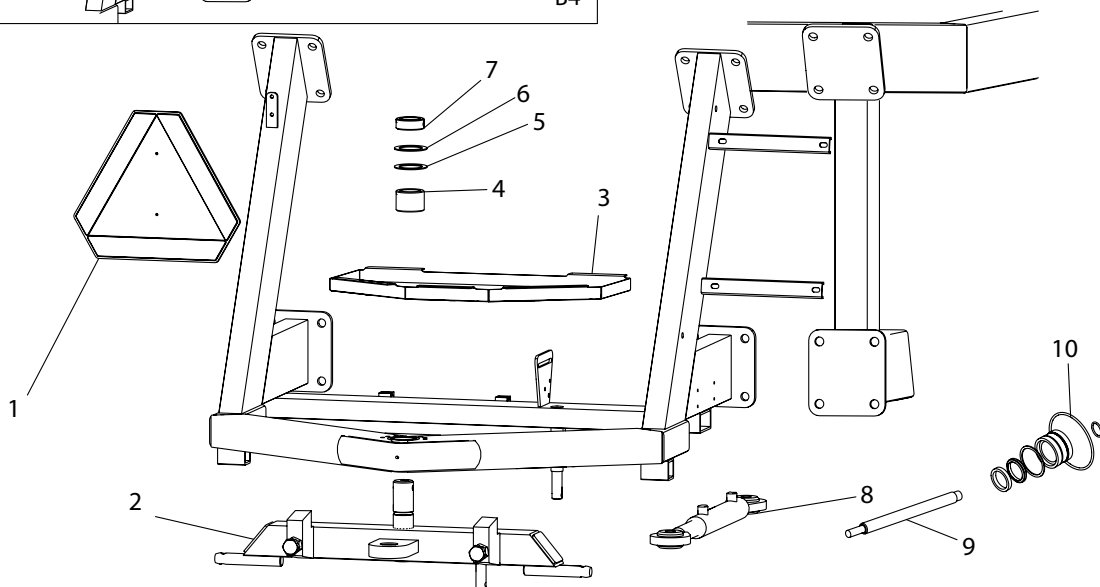

Item No.	Part No.	Qty	Description	Comments
1	1008966	1	Warning triangle	
2	1008250	1	Rear drawbar Comp	
3	1010520	1	Base plate for tool box	
4	1008101	3	Bushing	
5	895630	7	Support ring	
6	1008198	7	Spacer washer	
7	1008195	1	Stop ring	
8	1008585	1	Cylinder for forced steering	
9	1008585-2	1	Piston rod for cylinder	
10	1008585-1	1	Gasket set for cylinder	
11	022210080	1	M10 x 80 Steel set bolt	B1
12	761286-2	1	Lubrication cap	B1
13	761286	1	Lubrication nipple	B1
14	044010	1	M10 Lock nut	B1
15	763642	1	Tractor split pin	B2 the same
16	022216045	16	M16 x 45 Steel set bolt	B4
17	044008	2	M8 Lock nut	B3
18	022208016	2	M8 x 16 Steel set bolt	B3
19	040416	16	M16 Lock nut	B4
20	1008614	2	Hyd. Hose for forced steering	B2 the same

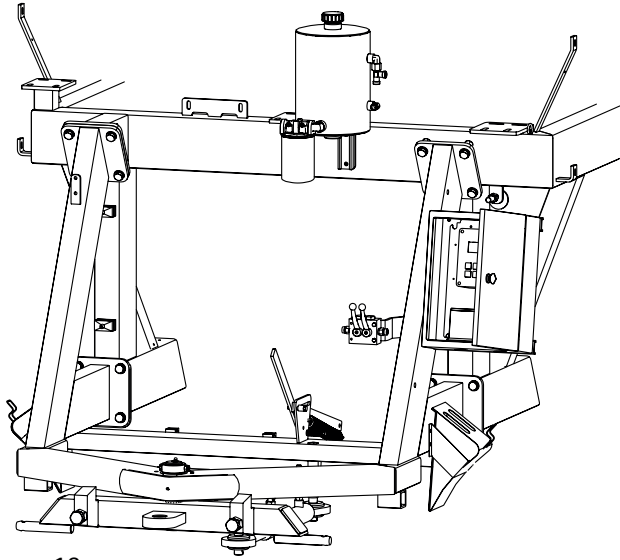

- 18
- 17
- 16
- 15
- 14
- 13
- 12
- 19
- 20
- 21
- 22
- 23

- 11
- 5
- 4
- 10
- 2
- 3
- 6
- 7
- 8
- 9

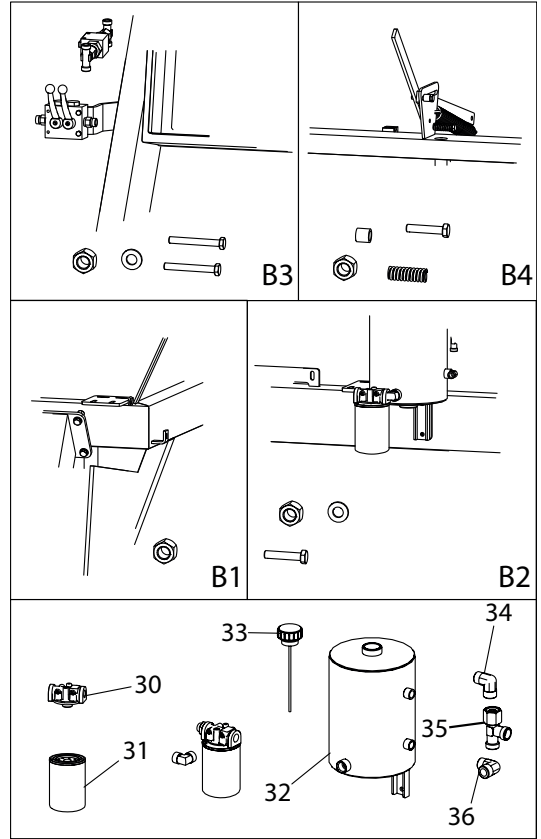

- 28
- 29
- 24
- 25
- 26
- 27
- 30
- 31
- 32
- 33
- 34
- 35
- 36

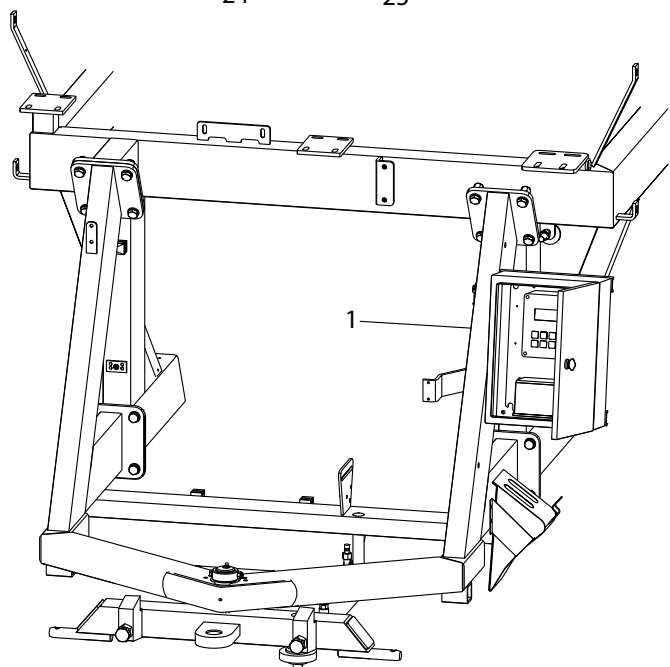

Item No.	Part No.	Qty	Description	Comments
1	1009150	1	Rear drawbar	
2	1011011	1	Drawbar spring	
3	2006359-1	1	Release arm	
4	68006	1	Rubber grip	
5	1009250	1	Lever for decoupling	
6	1005805	2	Holder for stop wedge	
7	1005800	2	Stop wedge	
8	1007540	2	Angle Cyl	
9	1010750	1	Ball valve for Dual pump	
10	1007514	2	Hose carrier	
11	1007510	1	Ball valve for decoupling	
12	051006	4	M6 Plain washer	B3
13	022206045	2	M6 x 45 Steel set bolt	B3
14	022210030	2	M10 x 30 Steel set bolt	B2
15	1009252	1	Compression spring for coupling	
16	022210080	1	M10 x 80 Steel set bolt	B4
17	022206055	2	M6 x 55 Steel set bolt	B3
18	109101	1	Spacer for switch	
19	1008198	2	Spacer washer for Rear drawbar	
20	763910	4	M10 Riplock	B2
21	044006	4	M6 Lock nut	B3
22	040410	3	M10 Steel nut	B4 & B2
23	040416	2	M16 Steel nut	B1
24	1007590	1	Plate for battery	
25	1005521	1	Battery	
26	1007578	1	Electric box	
27	1007584	1	Lock for box	
28	1007549-1	1	Exchanger Prog Rain	
29	1007549-7	1	Prog. Rain.	
30	1007484	1	Filter housing	
31	1007482	1	Hydraulic filter	
32	1007490	1	Tank	
33	1007500	1	Tank Cover	
34	1007536	1	Angle	
35	1007526	1	Nipple	
36	1007540	1	Angle	

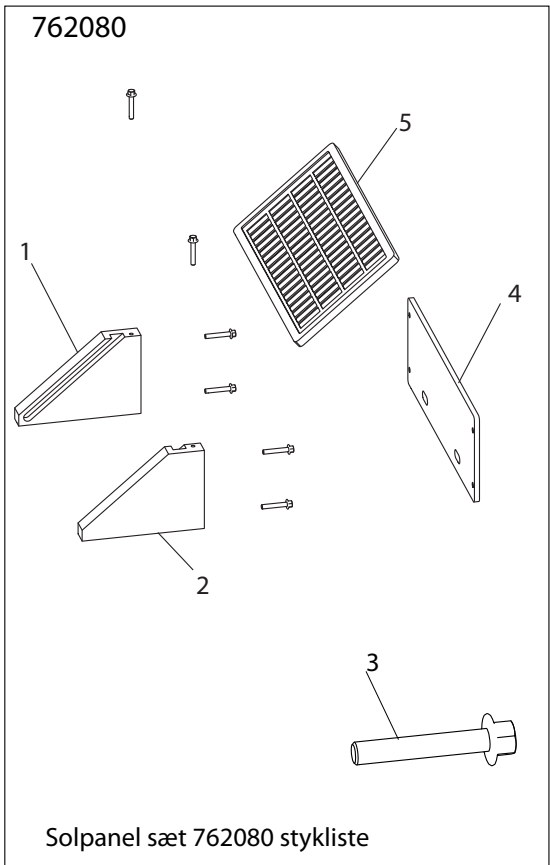
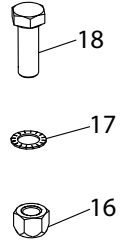
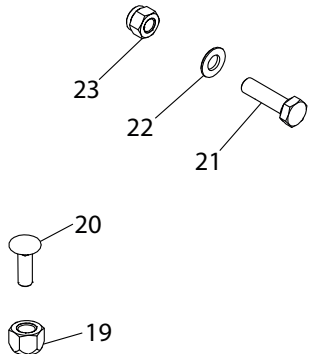
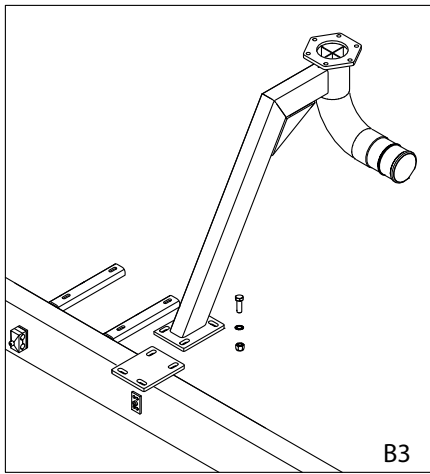
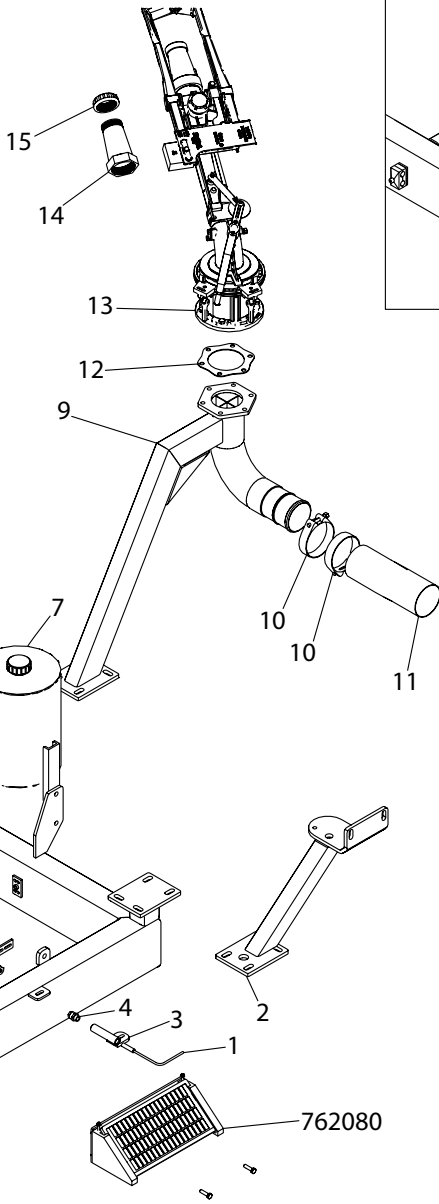
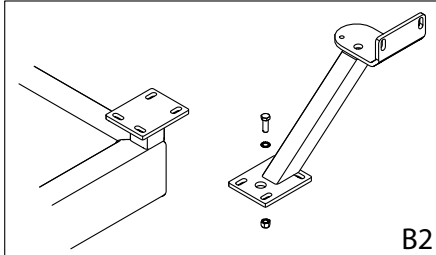
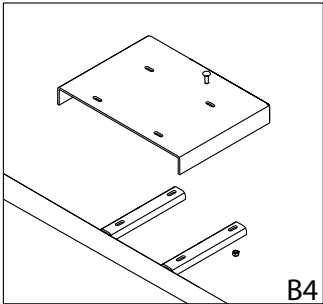
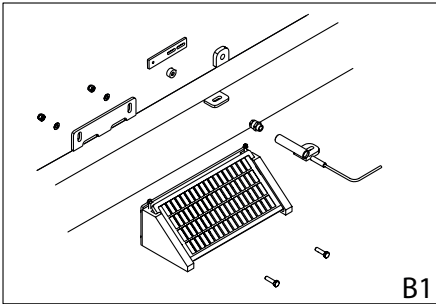

Item No.	Part No.	Qty	Description	Comments
1	1007560	1	Sensor	
2	1009120	1	Suspension for turbine	
3	1008265	1	Pipe for end stop sensor	
4	1005535	1	Cable coupling PG9 Sensor	
5	1005530	1	Magnet	
6	1009347	1	Bracket for sensor magnet	
7	1007490	1	Tank	
8	1010525	1	Top plate/lid	
9	1007655	1	Gun pipe 90 degrees	
10	16200726	2	Hose clamp	
11	1007910	1	Hose	Ø90x900 mm
12	761614	1	Flange gasket for gun	
13	770145	1	Gun Nelson SR-150	
14	7712781	1	150Tr Plastic body	
15	7712467	1	150Tr Plastic cap	
16	022212035	8	M12 x 35 Steel set bolt	
17	763912	16	M12 Riplock	
18	040412	8	M12 Steel nut	
19	040408	4	M8 Steel nut	
20	035208025	4	M8 x 25 Carriage bolt	
21	022208030	4	M8 x 30 Steel set bolt	B1
22	050312	8	M12 Plain washer	
23	044008	4	M8 Lock nut	B1
24	7712701	1	Complete nozzle	

## Parts list 762080 Solar panel

Item No.	Part No.	Qty	Description	Comments
1	2001259	1	Holder for solar cell L	
2	2001260	1	Holder for solar cell R	
3	510555	1	Ø4.8 x 32 SuperTEKS 6	
4	2002533	1	Galvanized plate for solar panel	
5	1005523	1	Solar panel for constant	

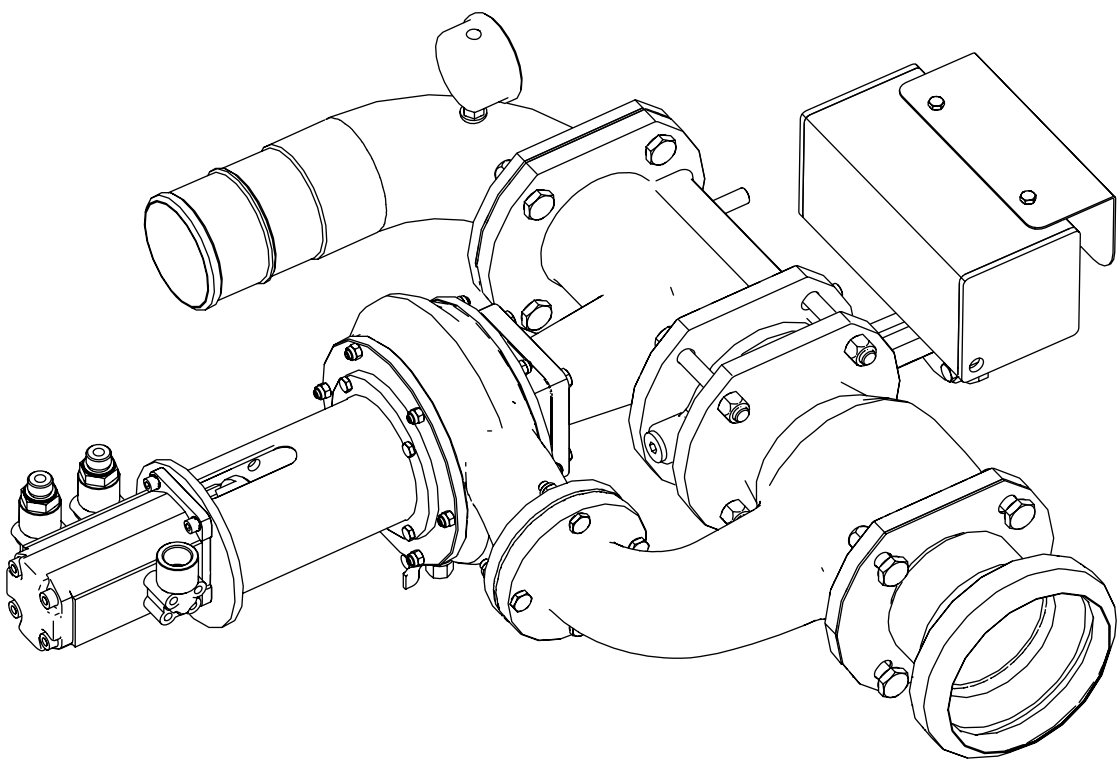





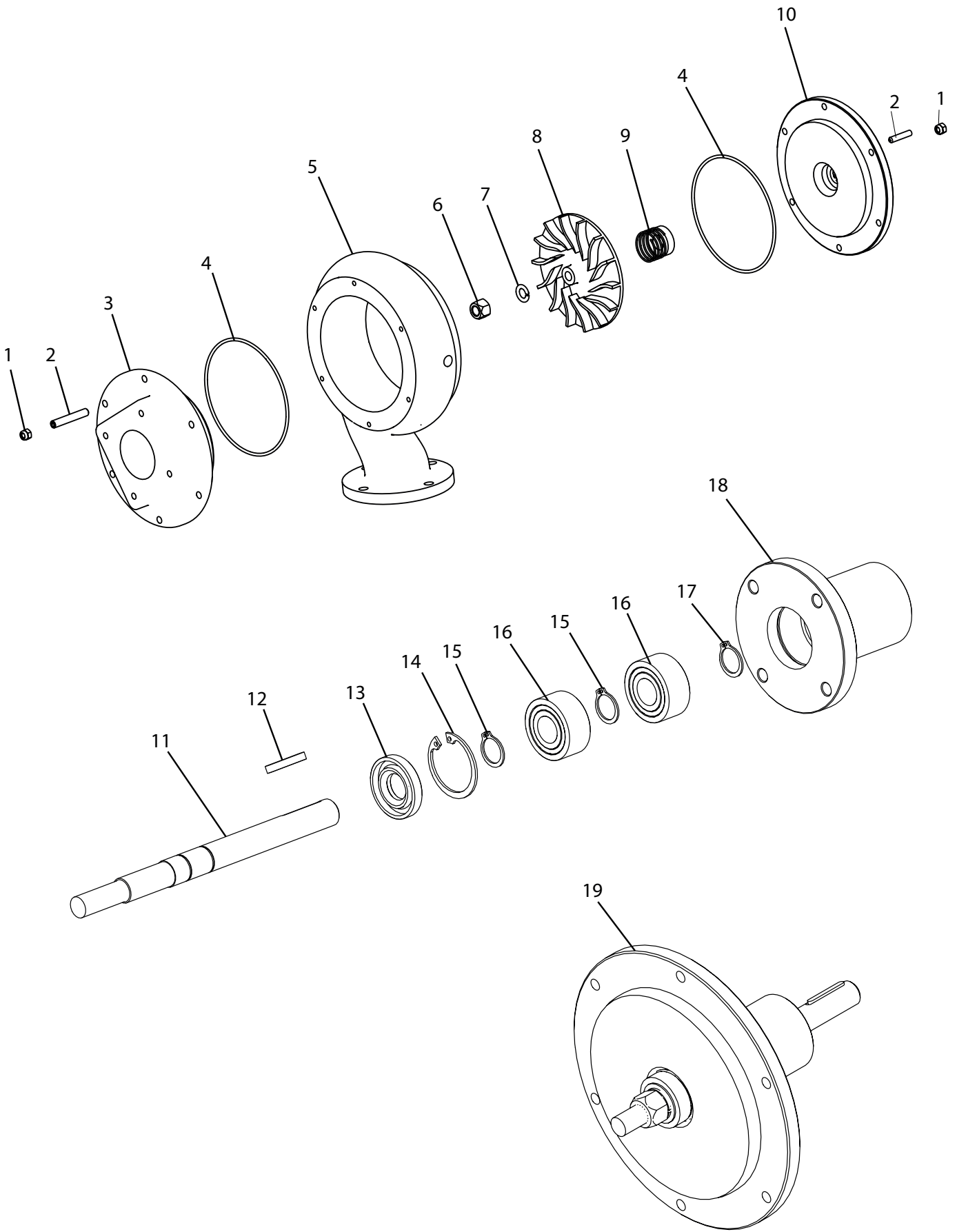

Item no.	Part No.	Qty	Description	Comments
1	095906	16	M6 Lock nut	
2	096506029	16	M6 x 29 Support bolt Pinol	
3	13000086	1	Upper flange turbine for top pipe	
4	195211	2	O-ring Cover seal	
5	195001	1	Turbine housing	
6	096012	1	M12 Nut	
7	096112	1	M12 Spring washer	
8	195031	1	Impeller	
9	P195201	1	Shaft seal for turbine	
10	195018	1	Packing block cover 20/50	
11	195036	1	Shaft	
12	195255	1	Key	4 x 4 x 29
13	195050	1	Sealing ring	
14	701035	1	Retaining ring Int.	
15	700015	2	Retaining ring Ext.	
16	195220	2	Front bearing	
17	517715	1	Clamping ring	
18	195013	1	Bearing housing	
19	195500	1	Turbine cover complete	
20	195000V	1	Complete turbine	

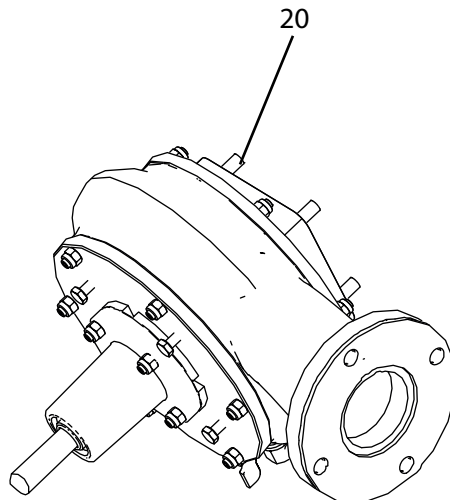

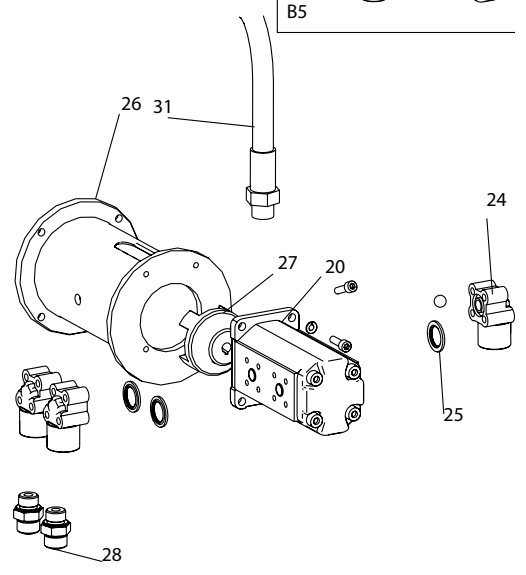
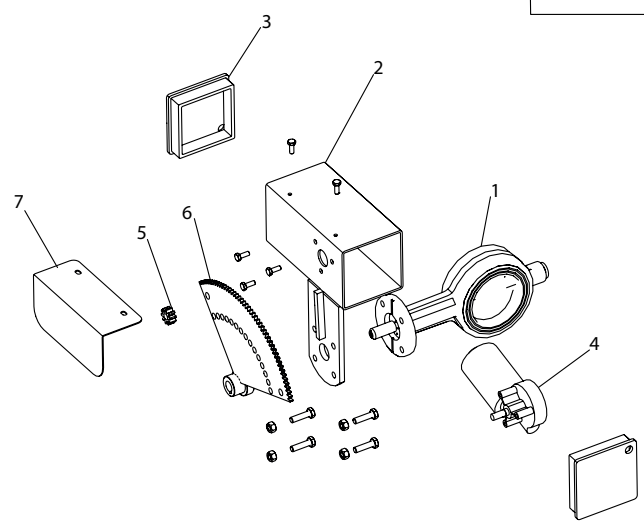
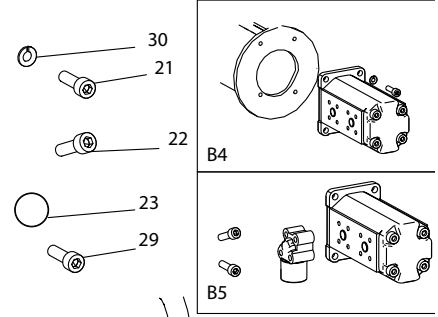
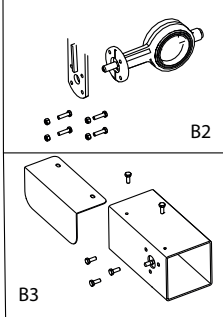
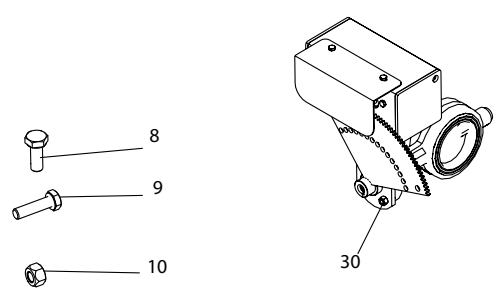
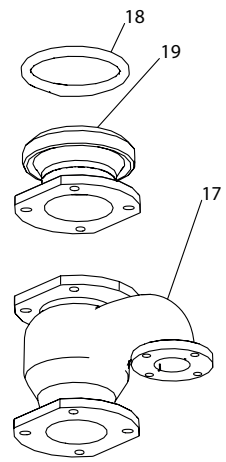
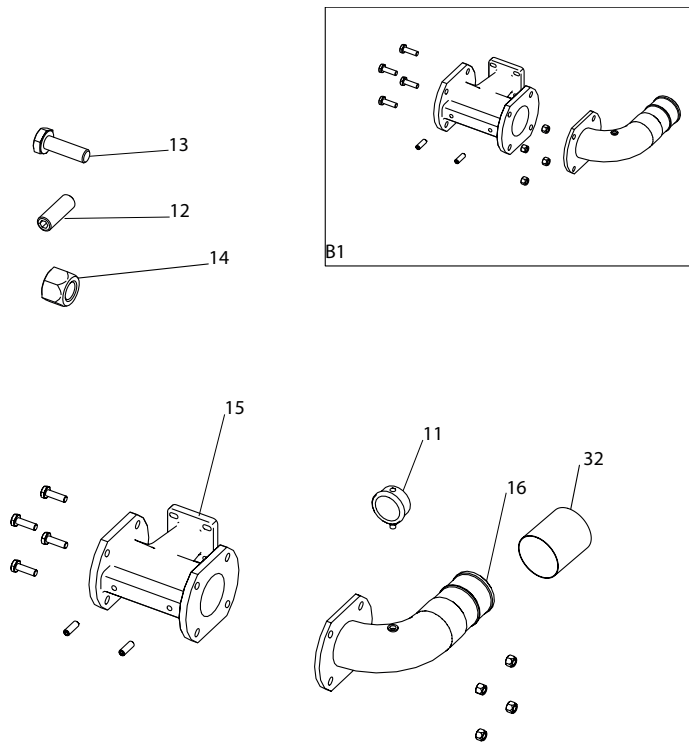

Item No.	Part No.	Qty	Description	Comments
1	1007250	1	Butterfly valve	
2	1007171	1	Motor housing for motor valve	
3	1007175	2	End plug for motor valve	
4	1007180	1	Motor for valve	
5	1007190	1	Gear for electric motor	
6	1007195	1	Gear for valve	
7	1007185	1	Guard for motor valve	
8	022206016	5	M6 x 16 Steel set bolt	B3
9	022208030	4	M8 x 30 Steel set bolt	B2
10	040408	4	M8 Steel nut	B2
11	1001163	1	Manometer glycerine	
12	763764	2	M12 x 50 Int. hex	B1
13	021012040	4	M12 x 40 Int. hex	B1
14	040412	4	M12 Steel nut	B1
15	33000227	1	Outlet pipe for turbine	
16	1009324	1	Flange with bend	
17	33000226	1	Base pipe for turbine	
18	14050043	1	Rubber ring	
19	1009328	1	Flange with HK cup	
20	1007415	1	Dual pump	
21	030506040	6	M6 x 40 Int. hex	B5
22	030506030	6	M6 x 30 Int. hex	B5
23	2.62 x 15.08	3	O-ring	
24	1007420	3	Flange for oil pump	
25	552024	3	Sealing ring 1/2	
26	1007110	1	Flange for pump	
27	1007450	1	Coupling part	
28	1007726	2	Nipple 1/2	
29	030506020	4	M6 x 20 Int. hex	B4
30	056206	4	M6 Spring washer	B4
31	1008605	1	Hydraulic hose 1/2	
32	16050210	1	Soft hose no. per running metre	530 mm
33	1007230	1	Comp Motor valve	

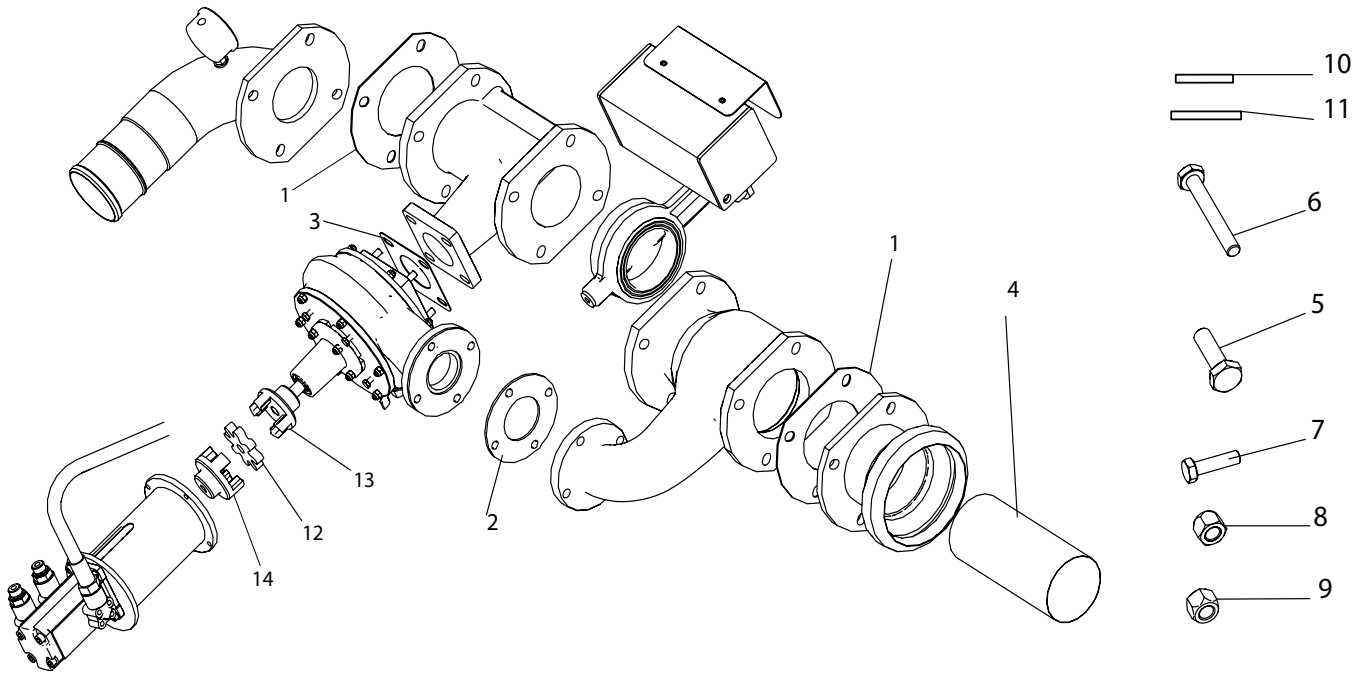
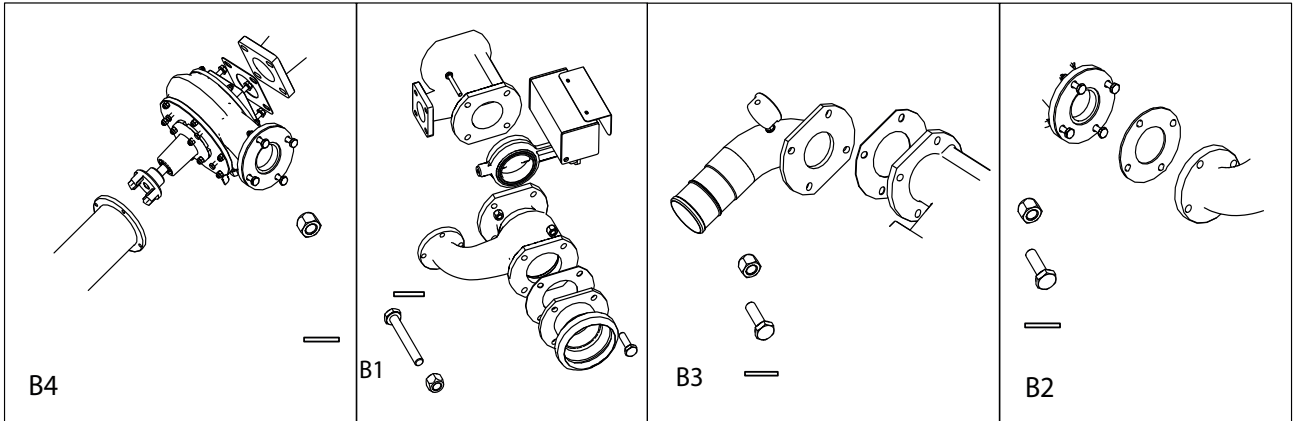

Item No.	Part No.	Qty	Description	Comments
1	631109	2	Flange gasket	
2	522085	1	Flange gasket	
3	631955	1	Flange gasket	
4	1005753	1	Filter	
5	021008045	4	M8 x 45 Steel bolt	B2
6	021010095	4	M10 x 95 Steel bolt	B1
7	022210040	8	M10 x 40 Steel set bolt	B1 & B3
8	040408	12	M8 Steel nut	B2 & B4
9	040410	12	M10 Steel nut	B3 & B1
10	763908	16	M8 Riplock	B2 & B4
11	763910	24	M10 Riplock	B3 & B1
12	1007470	1	Rubber for coupling	
13	1007450	1	Claw coupling Turbine	
14	1007460	1	Claw coupling Oil motor	

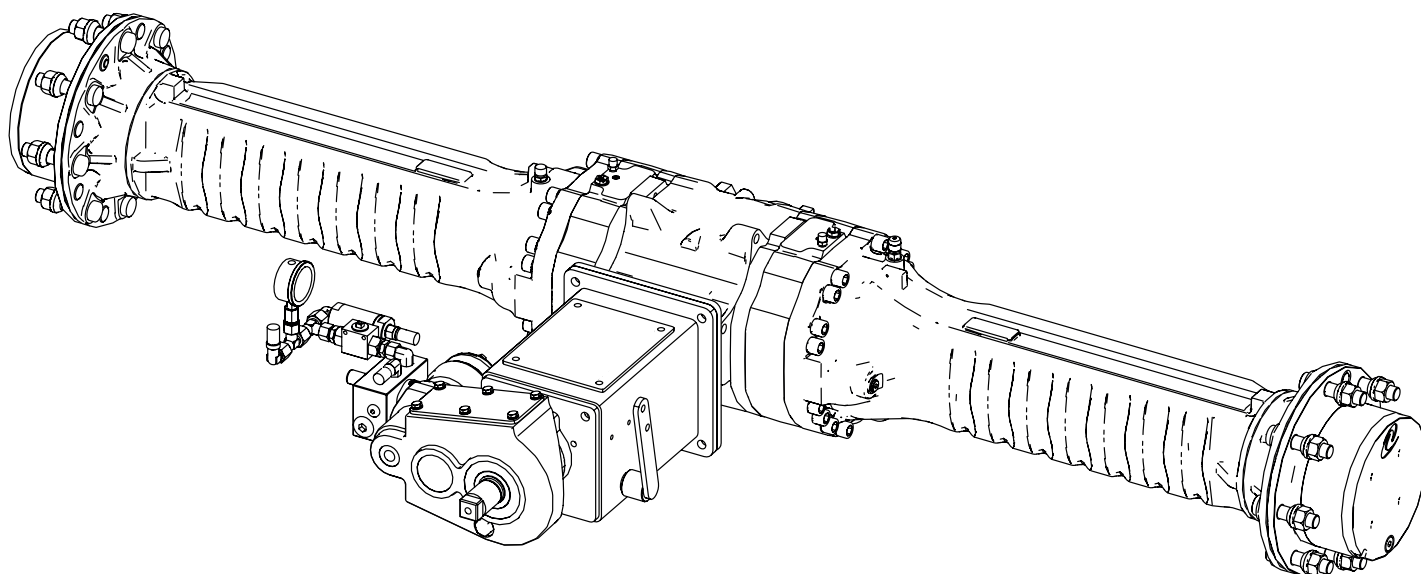





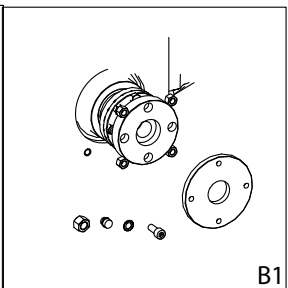
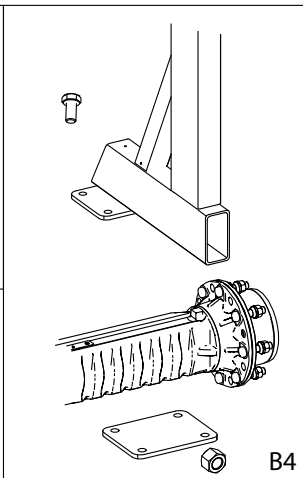
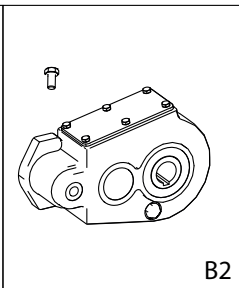
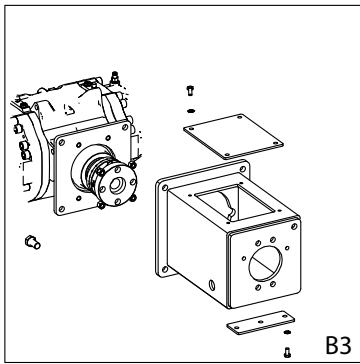

- 9
- 10
- 11
- 12
- 13
- 14
- 15
- 16
- 17

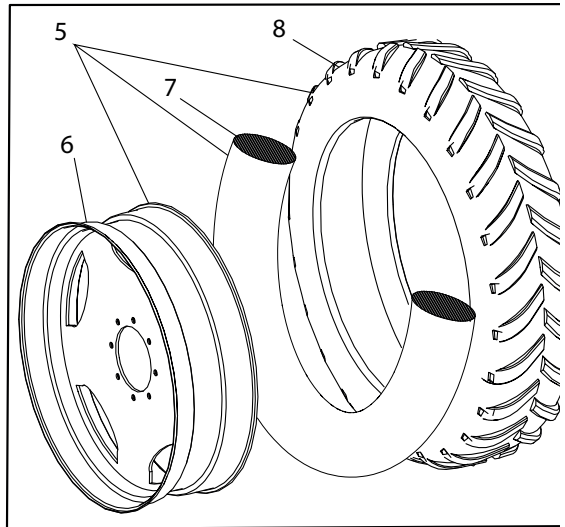
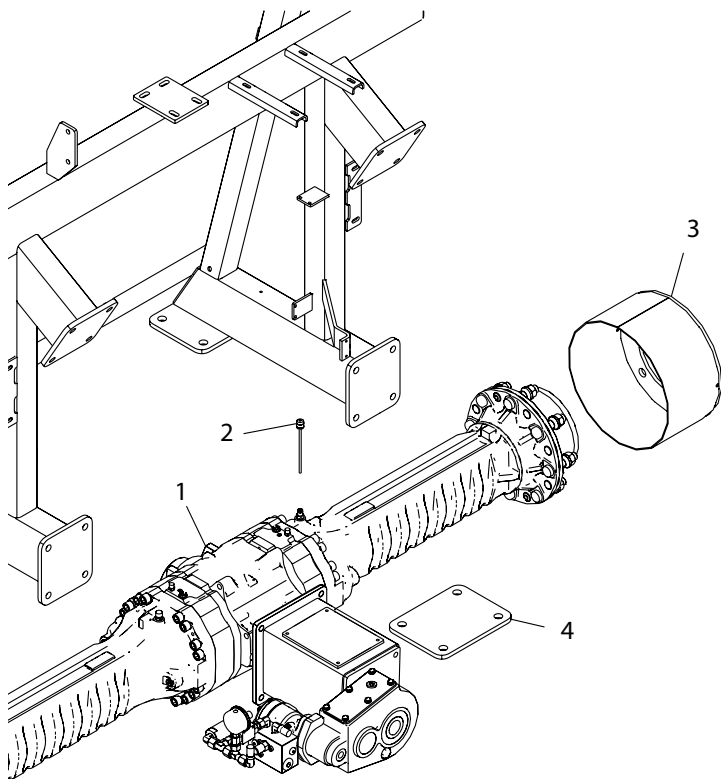

Item No.	Part No.	Qty	Description	Comments
1	2002813	1	Dipstick	
2	1009493	1	Rear axle assembly	
3	1009285	2	Tube	
4	2007776	2	Rim	
5	1008715	2	Hose	
6	1008710	2	Tyres	
7	1008769	2	Rear wheel Comp	
8	2002039-1	2	Bracket for rear axle assembly	
9	1007571	4	Magnet	B1
10	763770	4	M10 x 22 Unbraco	B1
11	763908	6	M8 Riplock	B3
12	022208016	12	M8 x 16 Steel set bolt	B3 & B2
13	763910	4	M10 Riplock	B1
14	021020220	8	M20 x 220 Steel bolt	B4
15	044020	8	M20 Lock nut	B4
16	022216030	4	M16 x 30 Steel set bolt	B3
17	044010	4	M10 Lock nut	B1

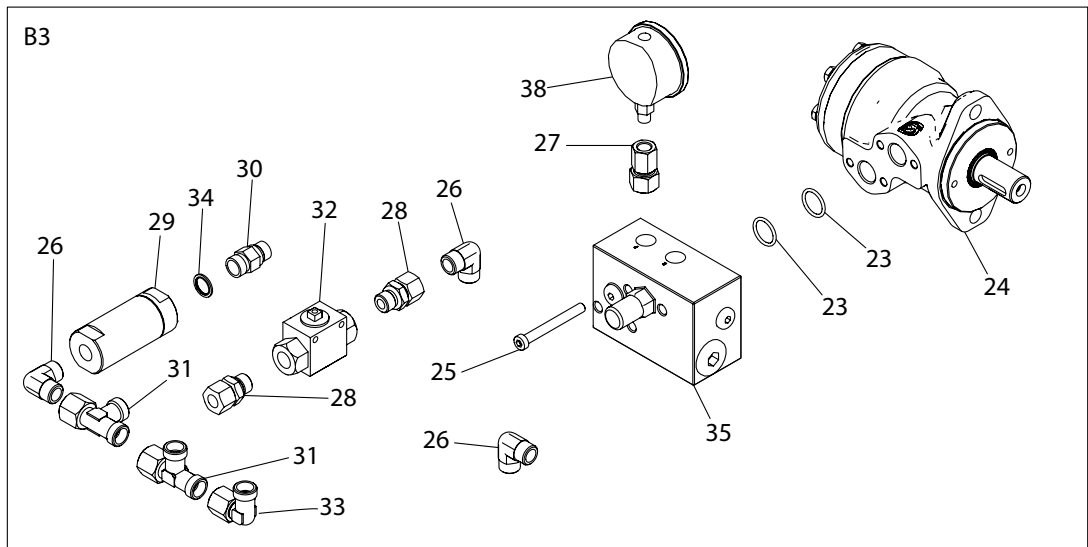
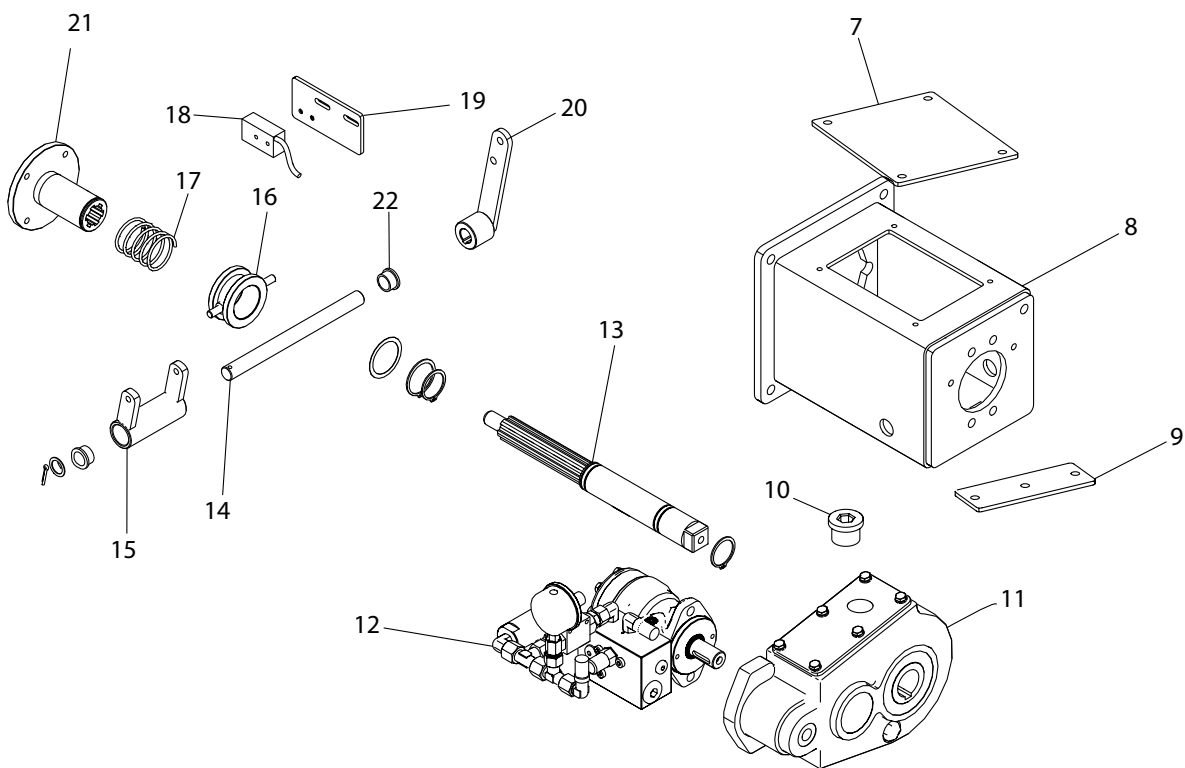
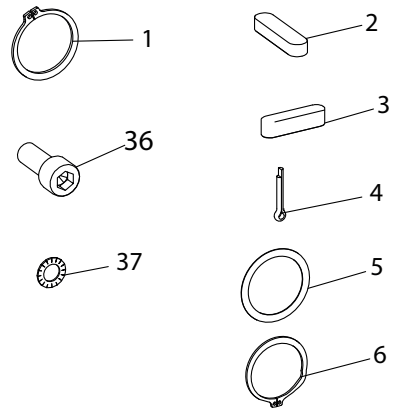
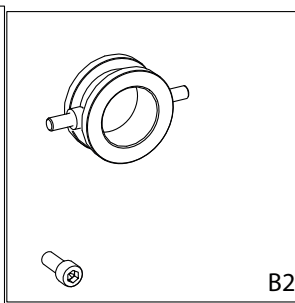
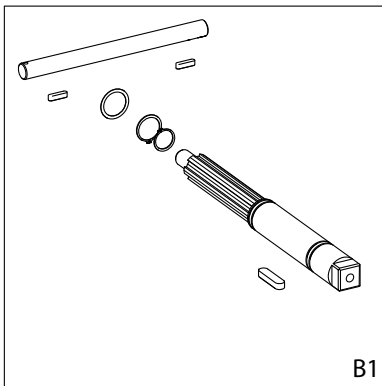

Item No.	Part No.	Qty	Description	Comments
1	700040	2	Retaining ring	
2	641625	2	Key	
3	641850	1	Key	
4	761010	1	Split pin	
5	1009222	1	Shim ring	
6	700048	1	Retaining ring	
7	1009205	1	Cover	
8	2002057	1	Coupling housing	
9	1009207	1	Base cover	
10	1007728-5	1	Plug for flat gear	
11	1009500	1	Flat gear	
12	B3			
13	1009230	1	Shaft for coupling	
14	1009235	1	Shaft	
15	1009240	1	Shift fork	
16	1009225	1	Shift sleeve	
17	1009227	1	Compression spring	
18	1007561	1	Dual sensor	
19	1009255	1	Bracket for sensor	
20	1009245	1	Shift arm	
21	1009220	1	Coupling hub	
22	1009203	2	Bushing shaft	
23				
24	1007440	1	Oil motor	
25				
26	1007544	3	Angle	
27	1010979	1	Nipple straight	
28	890414	2	Nipple straight	
29	1010970	1	Filter	
30	1007724	1	Nipple straight	
31	1007531	2	Tee	
32	1007510	1	Ball valve	
33	1008622	1	Angle	
34	552025	1	Sealing ring	
35	1013950	1	Valve block	
36	763770	2	M10 x 22 Unbraco bolt	
37	763908	4	M8 Riplock	
38	761163-4	1	Manometer	

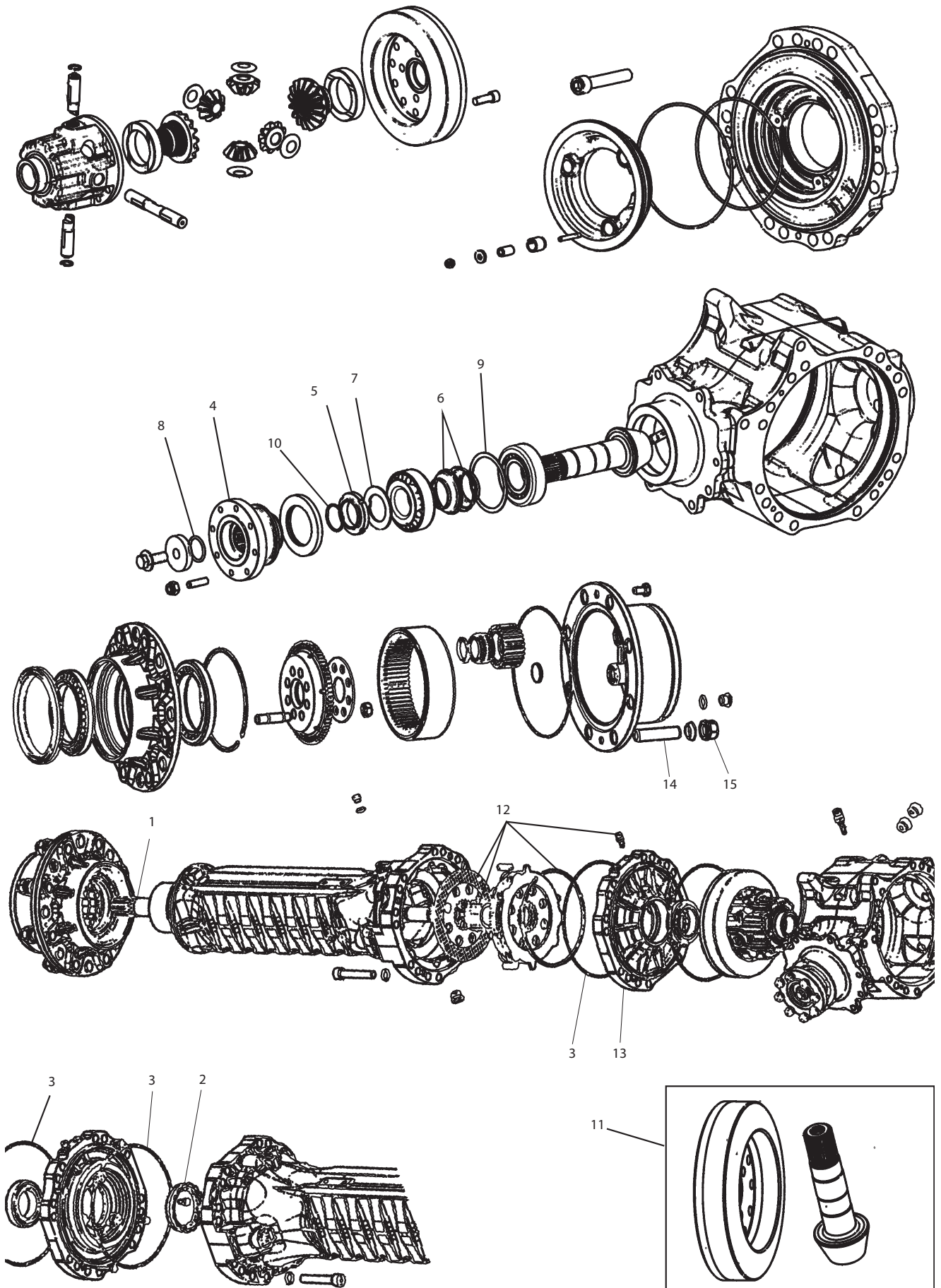

Item No.	Part No.	Qty	Description	Comments
1	1009588	2	Shaft FM4800H	
2	1009571	2	Ring nut	
3	1009572	4	O-ring 3.53 x 240.89	
4	1009573	1	Cardan flange	
5	1009574	1	Ring nut M40	
6	1009575	2	Spring cup	
7	1009576	1	Lock washer	
8	1009577	1	O-ring 3.53 x 29.75	
9	1009578	1	Shim washer Ø76	
10	1009579	1	Retaining ring without ears	
11	1009580	1	Crown/Pinion	
12	1009581	2	Brake Repair Set	
13	1009582	2	Pressure flange for brake	
14	1009455-6	18	Hub bolt M22 x 50	
15	1009456-4	18	Hub nut	

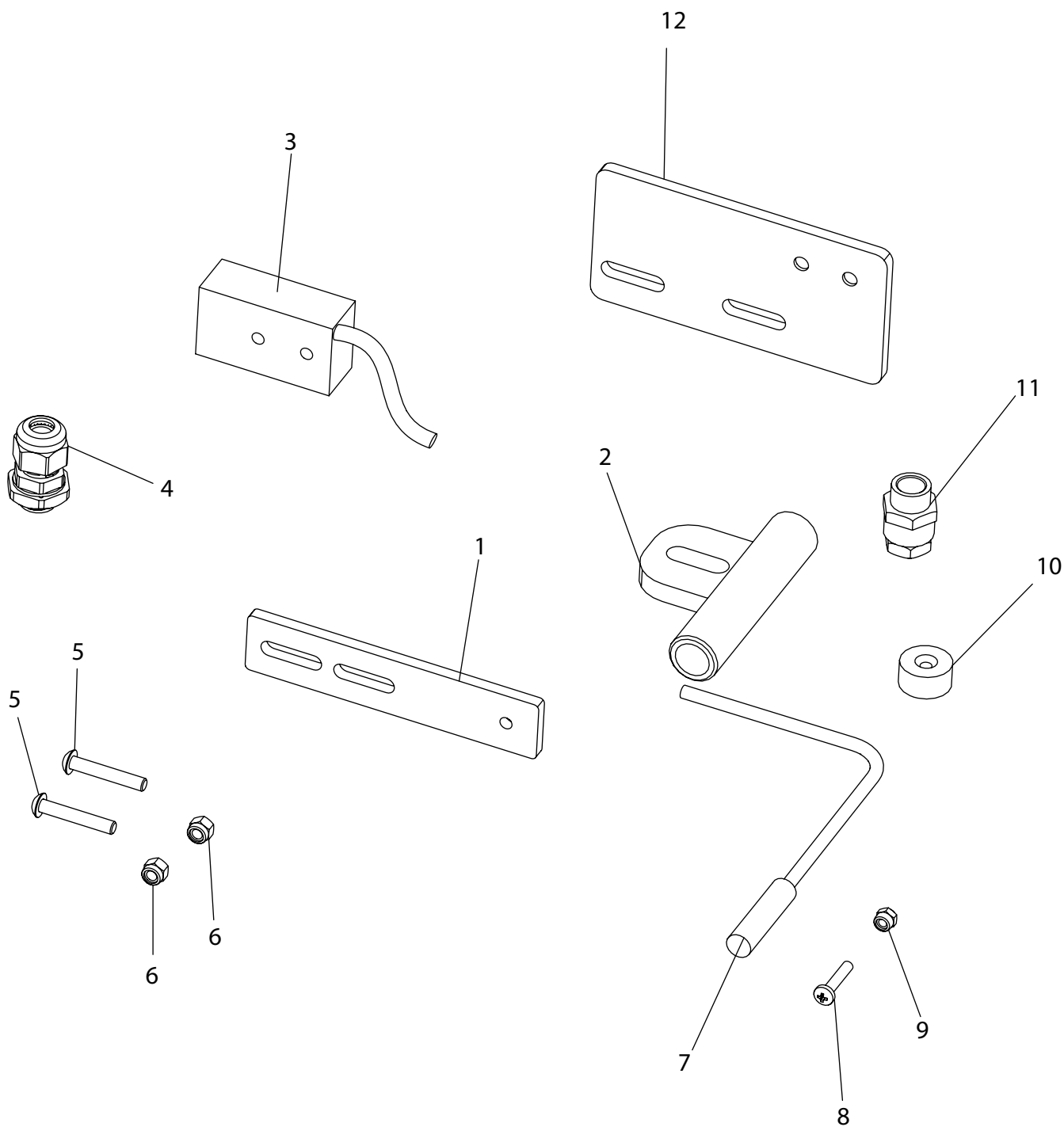



Item No.	Part No.	Qty	Description	Comments
1	1009347	1	Bracket for sensor magnet	
2	1008265	1	Pipe for end stop sensor	
3	1007561	1	Dual sensor	
4	1005535-1	1	Cable coupling Rear axle assembly	
5	763782	2	M5 x 30 Int. hex	
6	044005	1	M5 Lock nut	
7	1007560	1	Sensor	
8	034604020	1	M4 x 20 Machine screw	
9	044004	1	M4 Lock nut	
10	1005530	1	Magnet	
11	1005535	1	Cable coupling Sensor	
12	1009255	1	Bracket for coupling housing sensor	

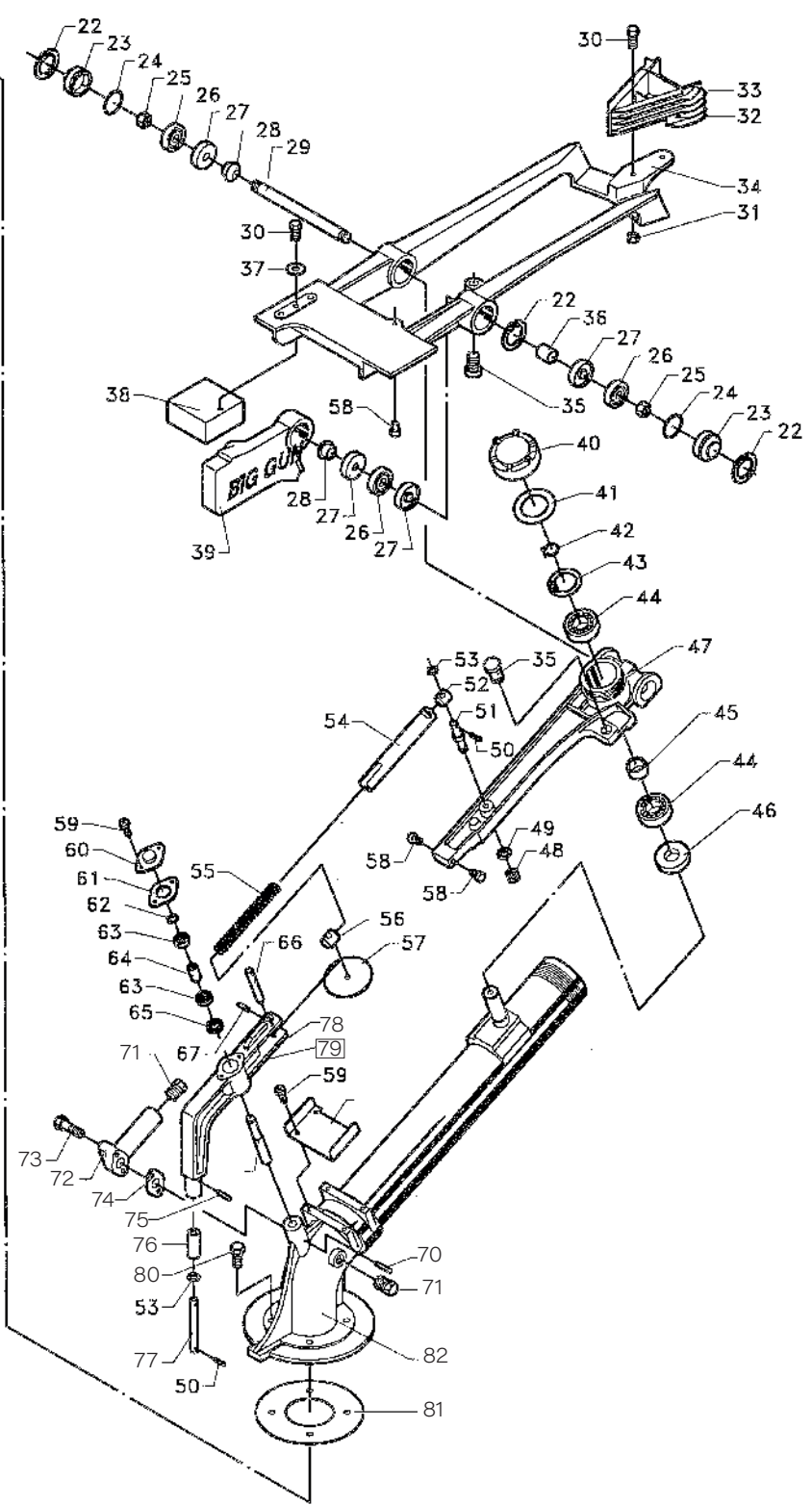
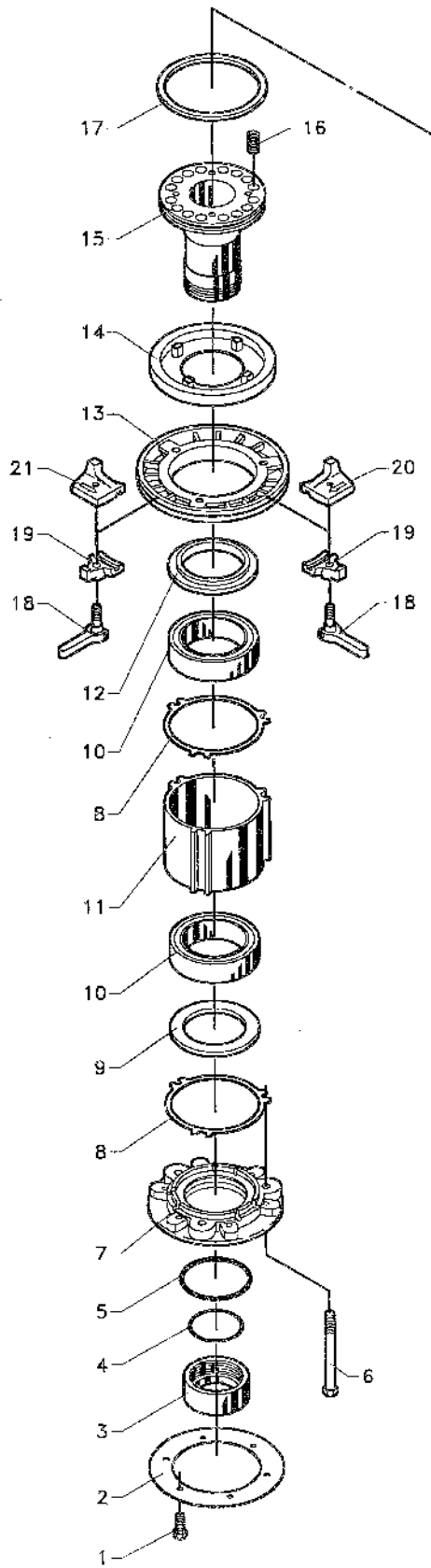

Item No.	Part No.	Qty	Description	Comments
1	776849	1	Bolt	
2	761614	1	Flange gasket for gun	
3	778402	1	Lock nut	
4	776548	1	O-ring	
5	778475	1	O-ring	
6	778462	3	Bolt	
7	778401	1	Base piece	
8	778461	2	Gasket	
9	778373	1	Sealing ring	
10	776253	2	Ball bearing	
11	778405	1	Bearing housing	
12	778372	1	Sealing ring	
13	778400	1	Brake disc	
14	778371	1	Brake lining	
15	778459	1	Bearing pipe	
16	778474	12	Spring	
17	778473	1	Sealing ring	
18	776849	2	Bolt	
19	776371	2	Bracket	
20	778432	1	Wheel chock Left	
21	778431	1	Wheel chock Right	
22	776565	3	Retaining ring	
23	776602	2	End cover	
24	776563	2	O-ring	
25	776603	2	Nut	
26	776598	3	Ball bearing	
27	776600	4	Sealing ring	
28	776607	2	Spacer pipe	
29	778465	1	Shaft	
30	776818	2	Bolt	
31	776060	2	Nut	
32	778354	1	Drive blade	
33	779229	1	Drive blade Topspeed	
34	778364	1	Drive arm	
35	778139	2	Rubber stop	
36	778327	1	Spacer pipe	
37	776070	1	Flat washer	
38	778433	1	Weight block	
39	778366	1	Counterweight	
40	778233	1	Cover	
41	778272	1	Gasket	

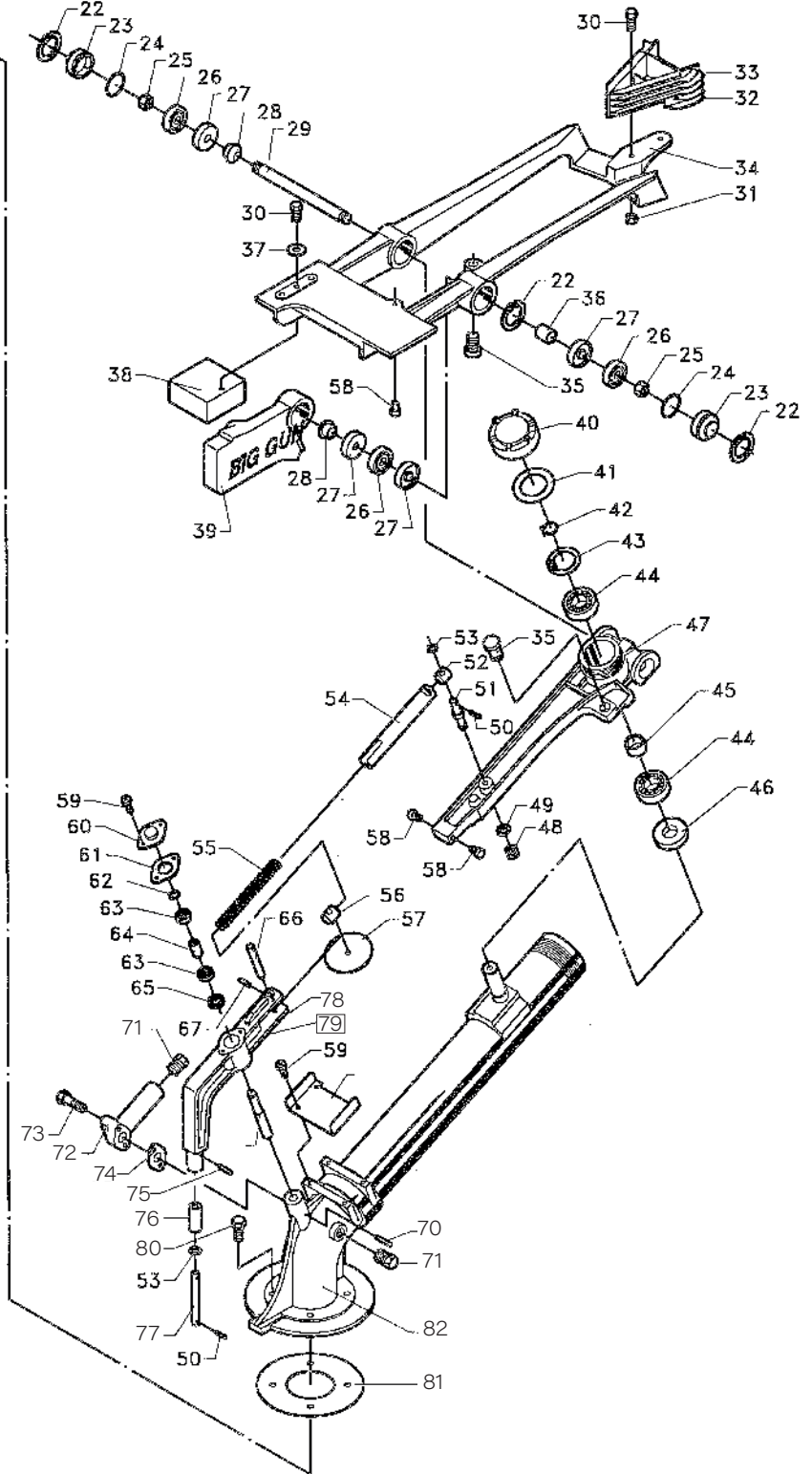
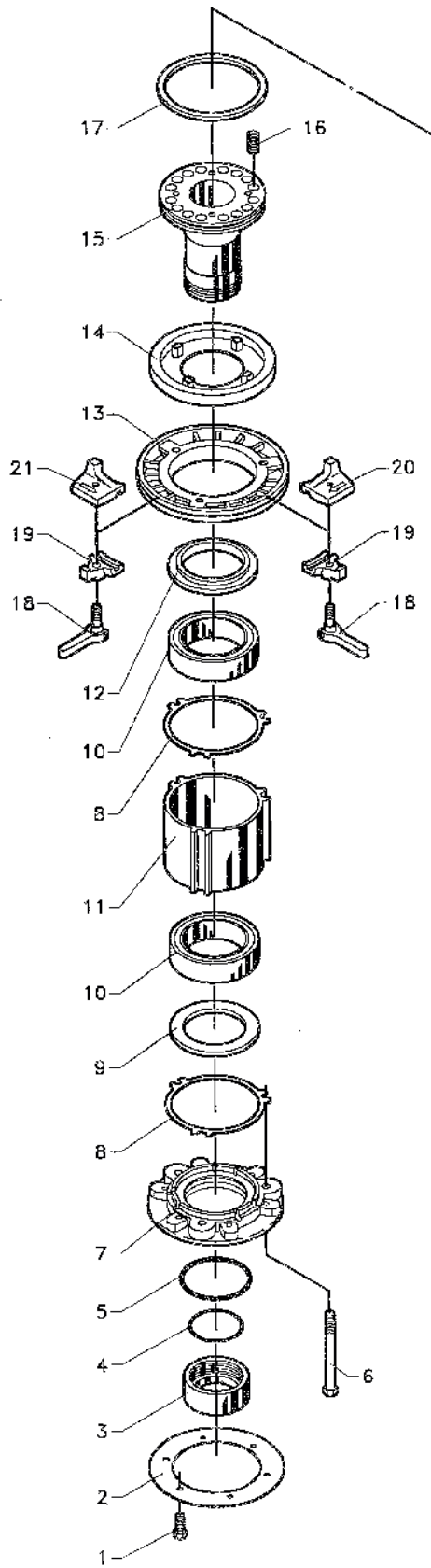

Item No.	Part No.	Qty	Description	Comments
42	778323-017	1	Retaining ring	
43	776045	1	Retaining ring	
44	776054	2	Ball bearing	
45	778326	1	Spacer pipe	
46	776048	1	Oil seal ring	
47	778394	1	Switch lever	
48	776064	1	Nut	
49	777029	1	Washer	
50	776714	2	Split pin	
51	778197	1	Bolt	
52	778282	1	Shaft	
53	778409	2	Flat washer	
54	778446	1	Pipe	
55	778470	1	Spring	
56	778417	1	Shaft	
57	778336	1	Washer	
58	776580	3	Stop pin	
59	778311	2	Screw	
60	778263	1	Cover	
61	778265	1	Gasket	
62	778323-004	1	Retaining ring	
63	778321	2	Bearing	
64	778281	1	Spacer pipe	
65	778317	1	Seal	
66	778193	1	Pin	
67	778320	1	Split pin	
68	778448	1	Plate	
69	778274	1	Shaft	
70	776931	1	Locking pin	
71	776089	2	Plug	
72	778497	1	Nozzle pipe	
73	776059	2	Bolt	
74	778511	1	Gasket	
75	778322	1	Split pin	
76	778277	1	Roller	
77	778276	1	Shaft	
78	778410	1	Arm trip lever	
79	778451	1	Complete switch	
80	778408	4	Bolt	
81	778460	1	Gasket	
82	778587	1	Jet pipe	





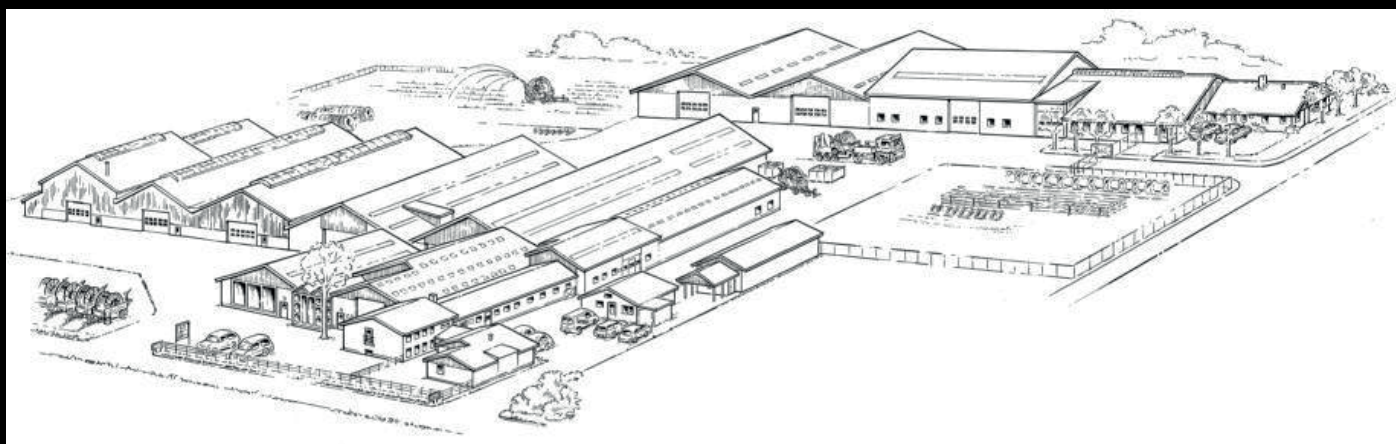

**FASTERHOLT**

**A/S FASTERHOLT MASKINFABRIK  
EJSTRUPVEJ 22, DK-7330 BRANDE  
DENMARK**

**TEL.: +45 97 18 80 66 FAX: +45 97 18 80 40**

**E-MAIL: MAIL@FASTERHOLT.DK**

**[www.fasterholt.dk](http://www.fasterholt.dk)**